

# Investigation of TESLA Damping Ring Kickers using the A0 Photoinjector Beam

George Gollin

Department of Physics

University of Illinois at Urbana-Champaign

USA

# Introduction

Linac beam (TESLA TDR):

- 2820 bunches, 337 nsec spacing (~ **300** kilometers)
- Cool an entire pulse in the damping rings before linac injection

Damping ring beam (TESLA TDR):

- 2820 bunches, ~20 nsec spacing (~ **17** kilometers)
- Eject every  $n^{\text{th}}$  bunch into linac (leave adjacent bunches undisturbed)

Damping ring vacuum of  $10^{-10}$  requires a pump every 4 meters. That's expensive!

Kicker speed determines minimum damping ring circumference.

# Introduction

Some of us got a look at the current TESLA kicker switch at DESY in April...

A faster kicker (of a different design) would allow a smaller DR design.

Fast kicker must eject beam without destroying its emittance.

We have ideas, but they need testing!

General principle for the kicker(s): “Fourier series engineering”

# Participants

This project is part of the US university-based Linear Collider  
R&D effort (LCRD/UCLC)

## Fermilab

Leo Bellantoni

David Finley

Chris Jensen

George Krafczyk

Shekhar Mishra

François Ostiguy

Vladimir Shiltsev

## University of Illinois

Guy Bresler

Keri Dixon

George Gollin

Mike Haney

Tom Junk

Jeremy Williams

## Cornell University

Gerry Dugan

Joe Rogers

Dave Rubin

# TESLA damping ring kicker *à la* TDR

TDR design: bunch “collides” with electromagnetic pulses traveling in the opposite direction inside a series of traveling wave structures. Hard to turn on/off fast enough.

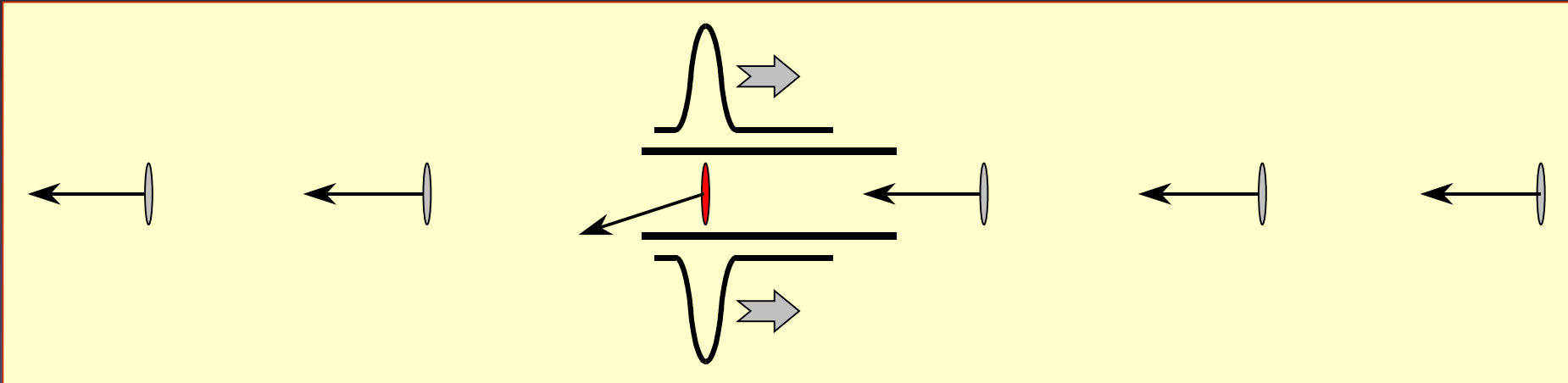

Fast kicker specs (*à la* TDR):

- $\int B dl = 100 \text{ Gauss-meter} = 3 \text{ MeV}/c (= 30 \text{ MeV}/\text{m} \times 10 \text{ cm})$
- stability/ripple/precision  $\sim .07 \text{ Gauss-meter} = 0.07\%$

# A different idea: “Fourier series kicker”

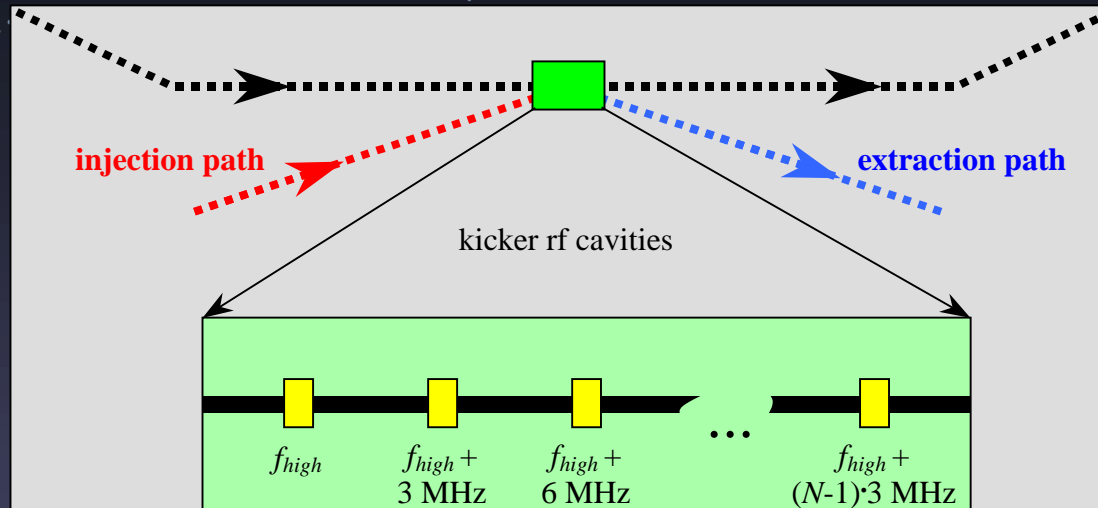

Kicker would be a series of  $N$  “rf cavities” oscillating at harmonics of the linac bunch frequency  $1/(337 \text{ nsec}) \approx 3 \text{ MHz}$ :

$$p_T = A \left[ \sum_{j=0}^{j=N_{\text{cavities}}-1} A_j \cos \left[ \left( \omega_{\text{high}} + j\omega_{\text{low}} \right) t \right] \right]; \quad \omega_{\text{low}} = \frac{2\pi}{337 \text{ ns}}$$

# Damping ring operation with an FS kicker

Kicker would be located in a bypass section. It is always on.

While damping, beam follows the upper path.

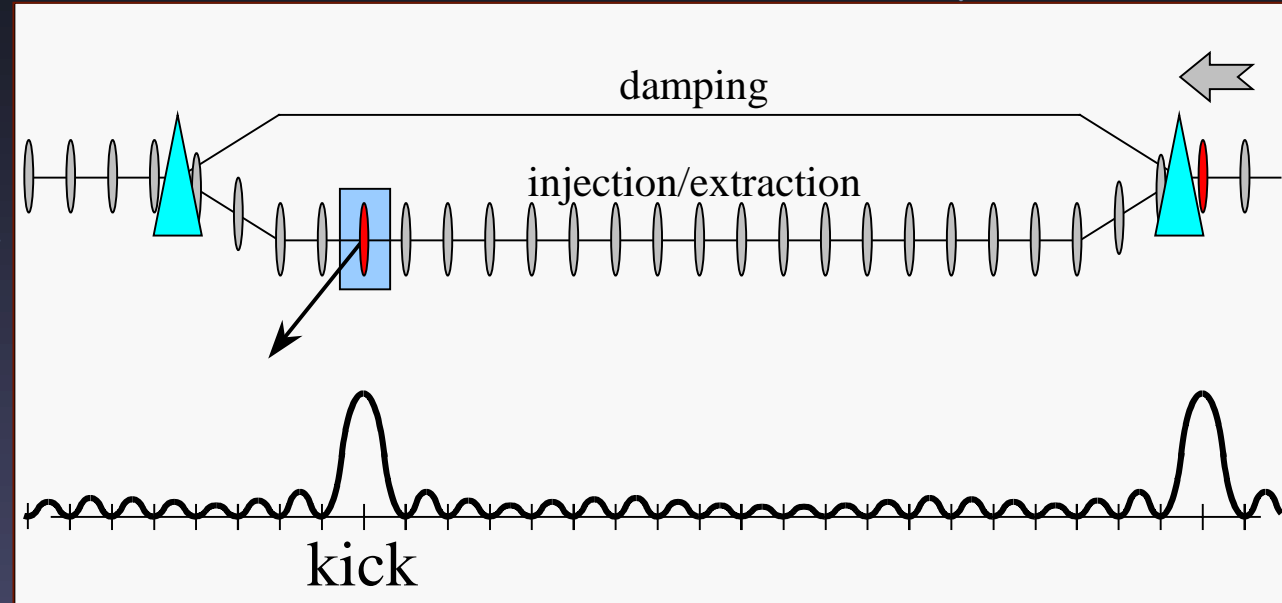

During injection/extraction, deflectors route beam through bypass section. Bunches are kicked onto/off orbit by kicker.

# First version

Run transverse kicking cavities at 3 MHz, 6 MHz, 9 MHz,... in phase with equal amplitudes. Unkicked bunches traverse kicker when field integral sums to zero. It's the bunch which sums the impulses from the individual cavities.

Problems with this:

- slope at zero-crossings might induce head-tail differences
- LOTS of different cavity designs (one per frequency)

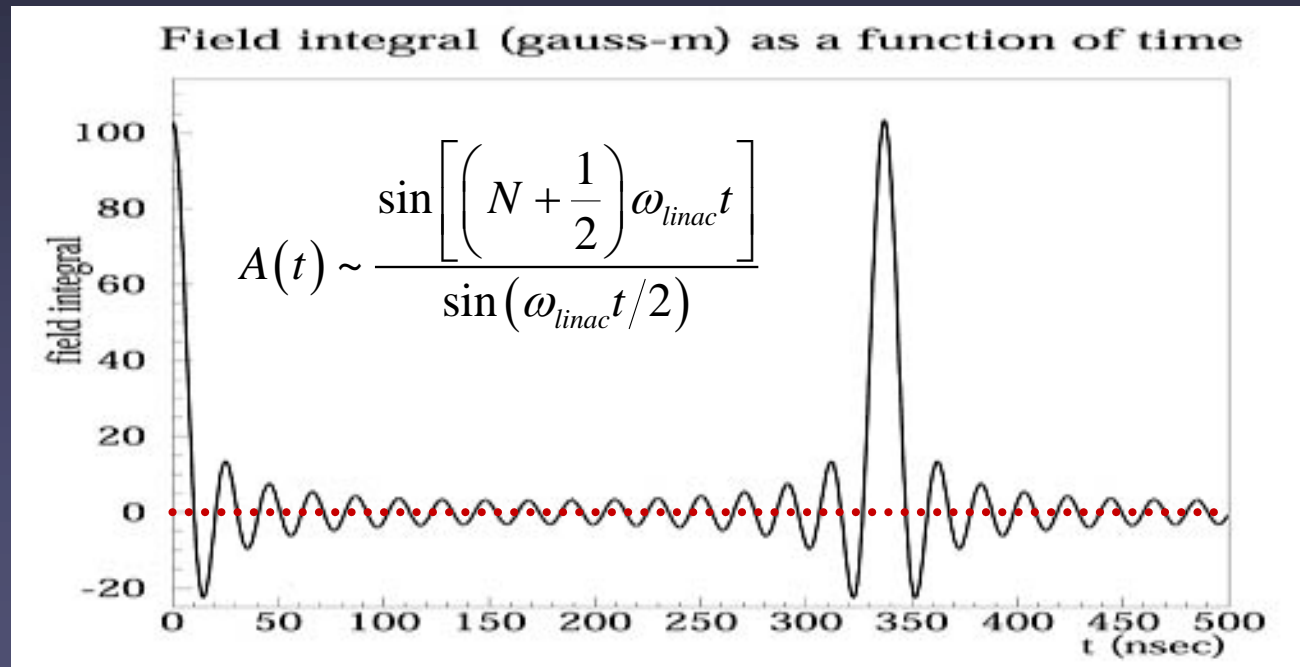

# A less naïve version

Run transverse kicking cavities at 3 MHz, 6 MHz, 9 MHz,... in phase with amplitudes which decrease linearly with frequency. This way, zeroes also have zero slope. That's good!

BUT this still requires lots of different cavity designs (one per frequency).

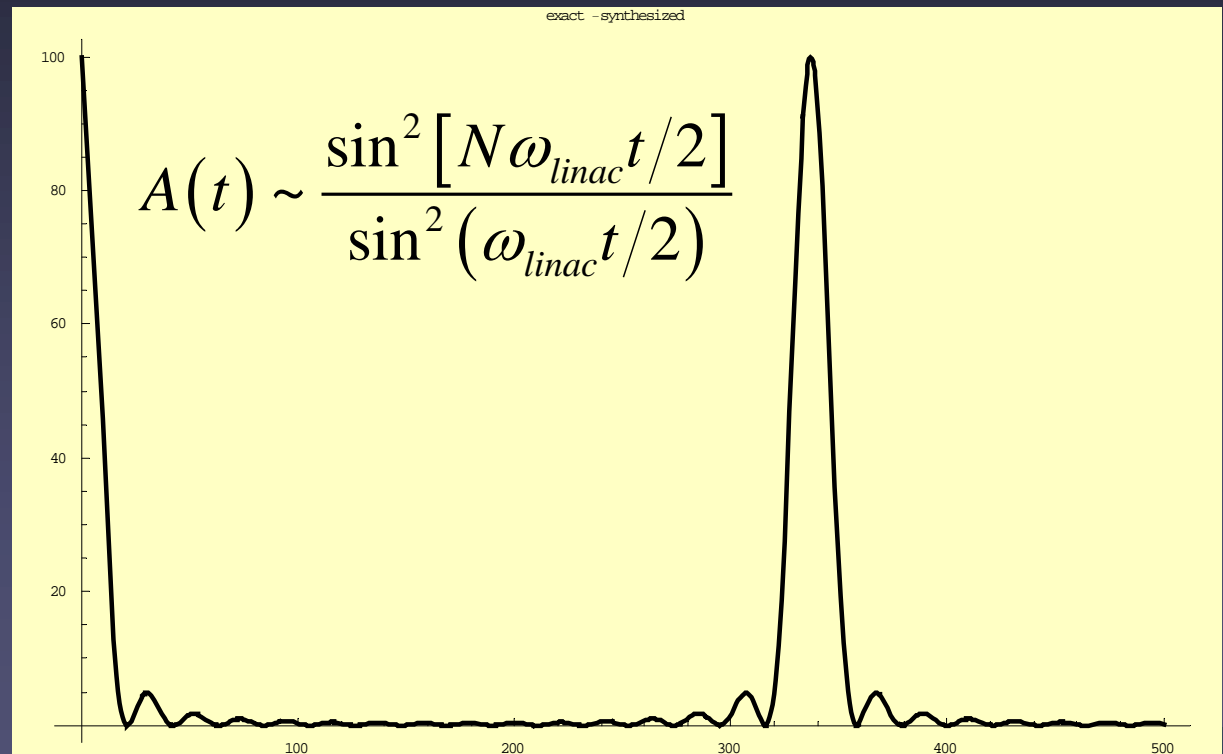

# Better idea: permits one (tunable) cavity design

Run cavities at much higher frequency; split the individual cavity frequencies by 3 MHz. (V. Shiltsev)

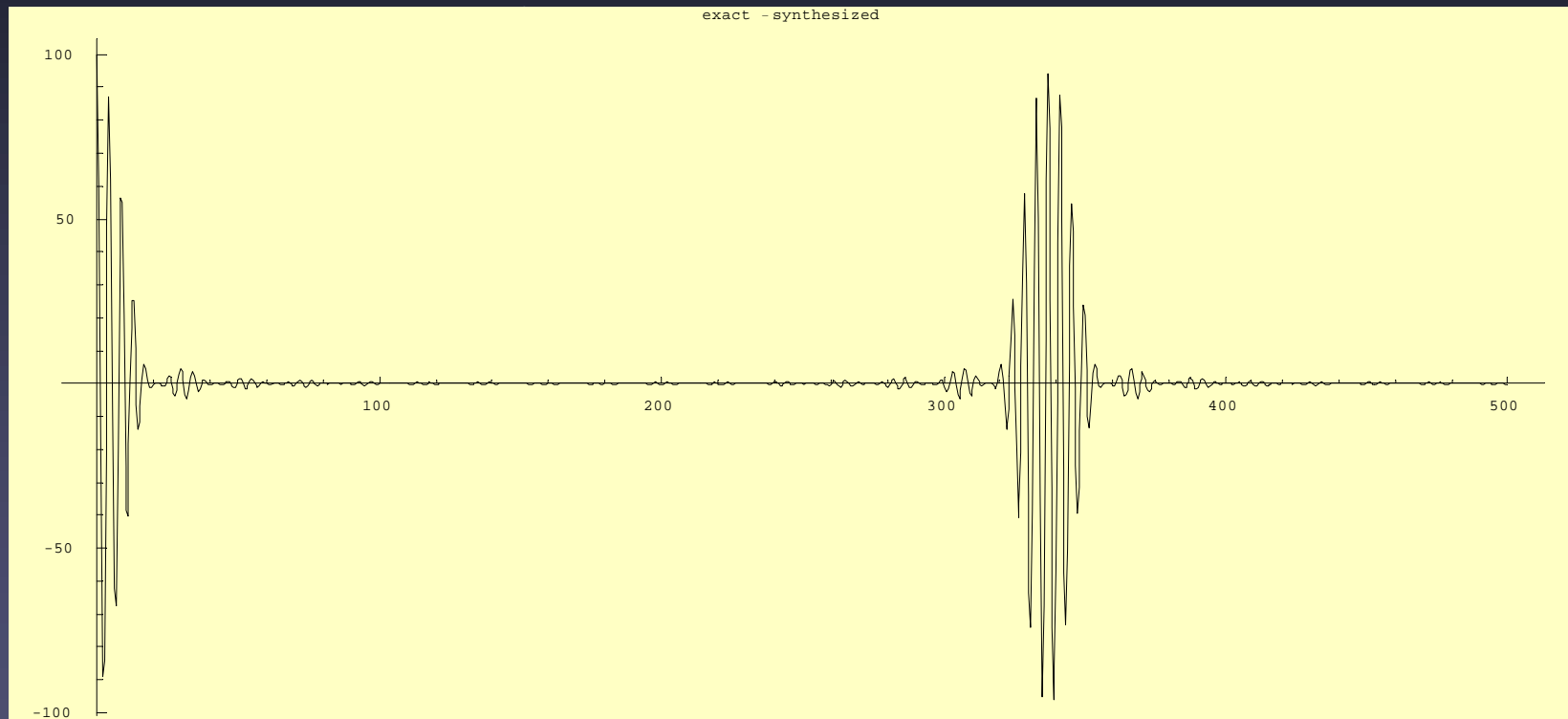

Still a problem: that's a lot of cavities! (~60 for a 6 km ring)

# Very elegant idea (from Joe Rogers)

Use a (single?) low-Q cavity to sum the various frequencies: low-Q so that the cavity supports a range of frequencies.

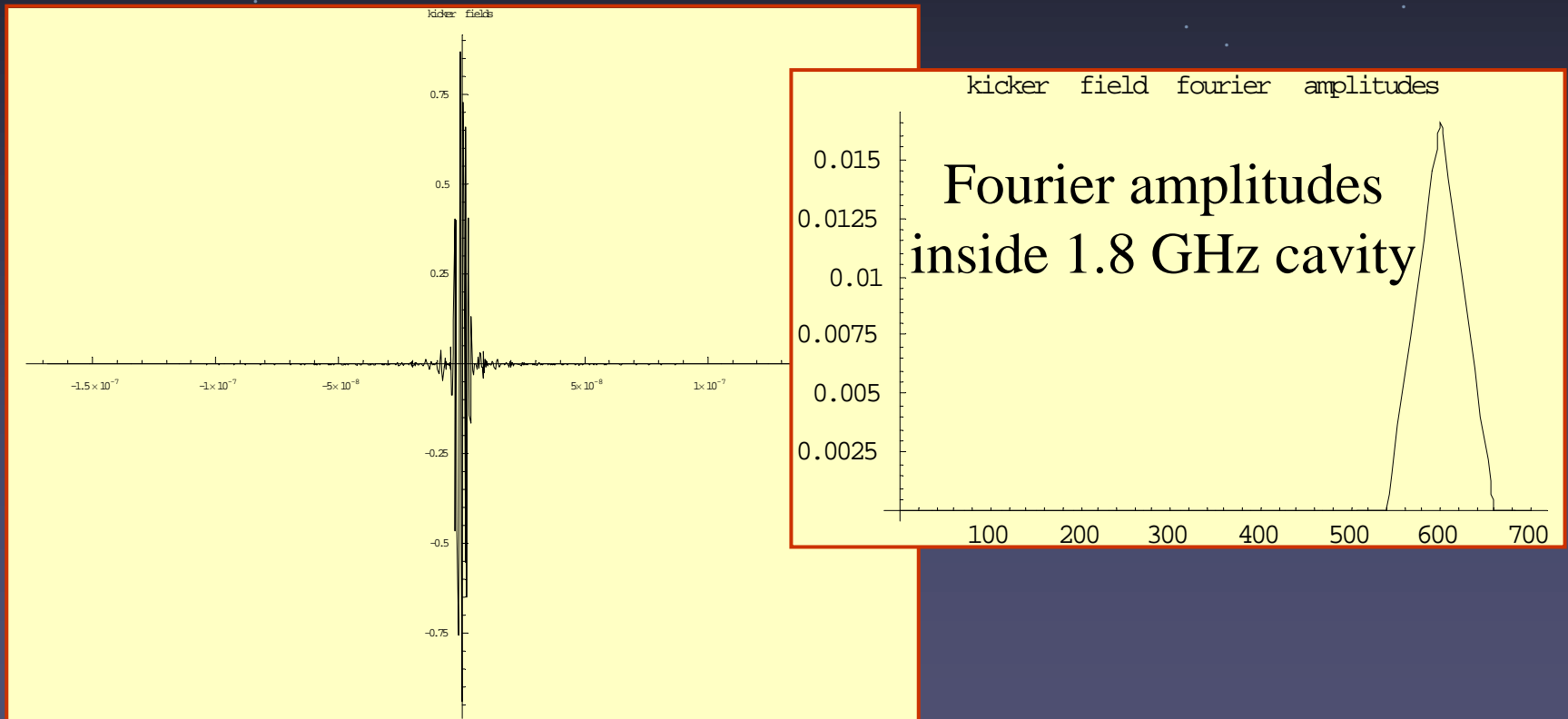

Still a problem: very large peak power...

# Reducing peak power

Use a (dispersive) wave guide to feed the power to the cavity. This was also Joe's idea.

With proper choice of input pulse shape, the wave guide's dispersion compresses the pulse.

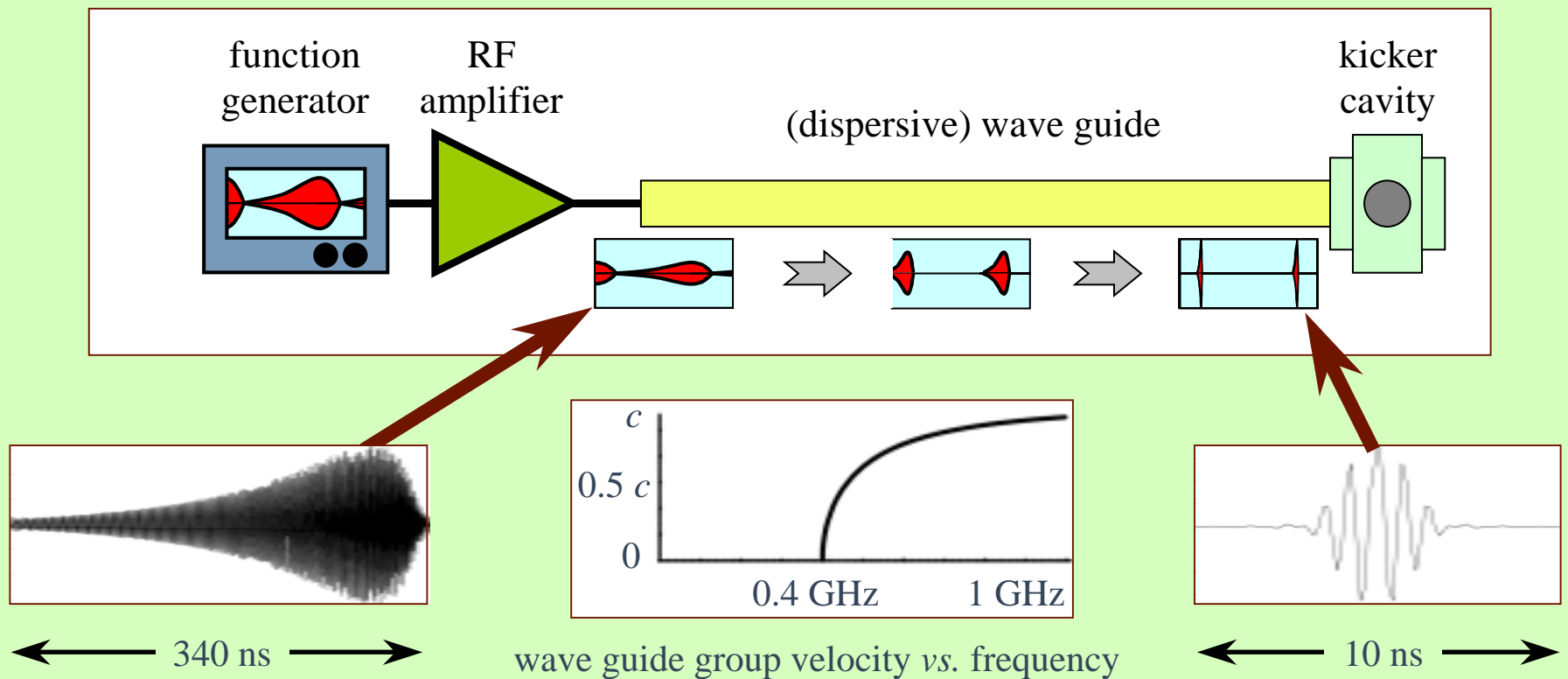

# Chirped waveform pulse compression kicker

Unlike Fourier series kicker, in which bunches “sum” the effects of different frequencies, this design uses the cavity to form the sum.

System is linear, so low-power tests can be used to evaluate concept. (Fermilab is interested in pursuing this.)

Programmable function generator can be reprogrammed to compensate for drifts and amplifier aging.

# Will this actually work?

There is work to do!

- Computer simulations of sensitivity to imperfections
- Investigation of RF issues: Does such an amplifier actually exist? Can RF circulators control reflections from the cavity? How stable can the system be?
- How well can we test a prototype? (A0 to the rescue!)

An initial step (in parallel with others) is to understand A0 photoinjector beam properties and learn how well we can use it to evaluate a simple kicker.

# Testing our kicker ideas

A0 photoinjector lab at Fermilab produces a relativistic, bunched low-emittance electron beam.

This should be an excellent facility for kicker studies!

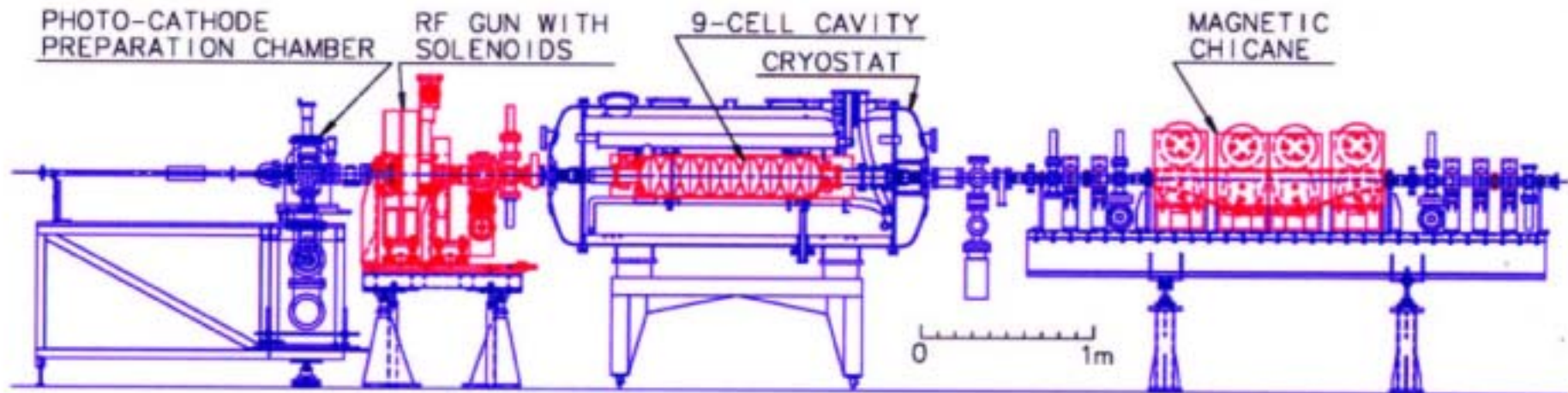

# Simple kicker for initial tests

Start with a simple kicker whose properties are calculable and can be measured independently of its effects on the A0 electron beam.

Most important: how well can we measure a device's amplitude and timing stability with the A0 beam?

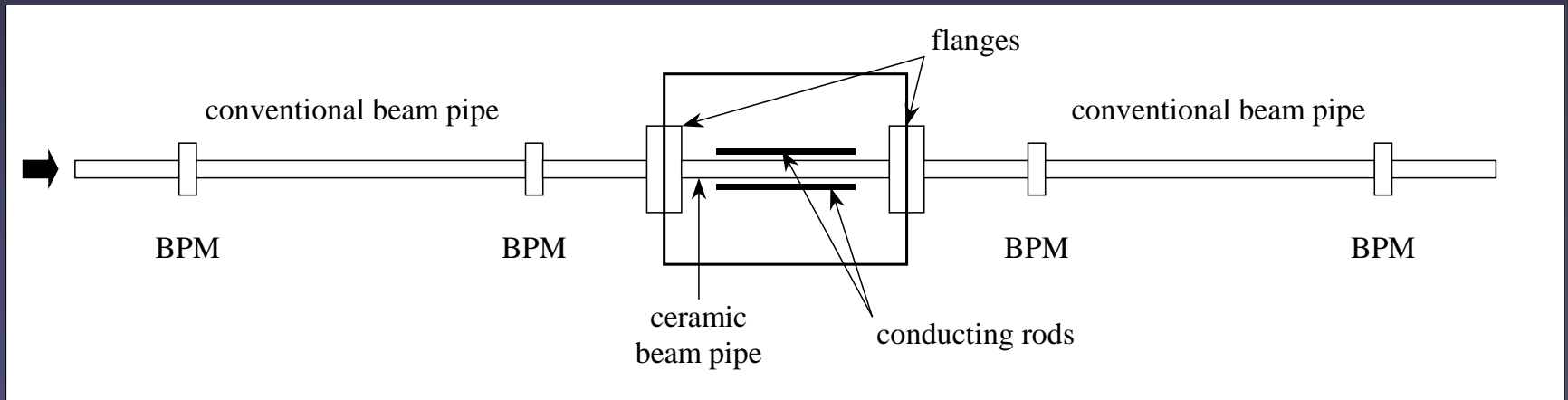

BPM's are separated by about a meter.

# Simple kicker

Driving kicker with  $\pm 750$  volt pulse from FNAL linac chopper pulser will deflect 16 MeV beam by 3.3 mrad. (See EOI for calculations.)

Two pairs of  $50 \mu$  resolution BPM's determine deflection to  $\pm 100 \mu$ rad

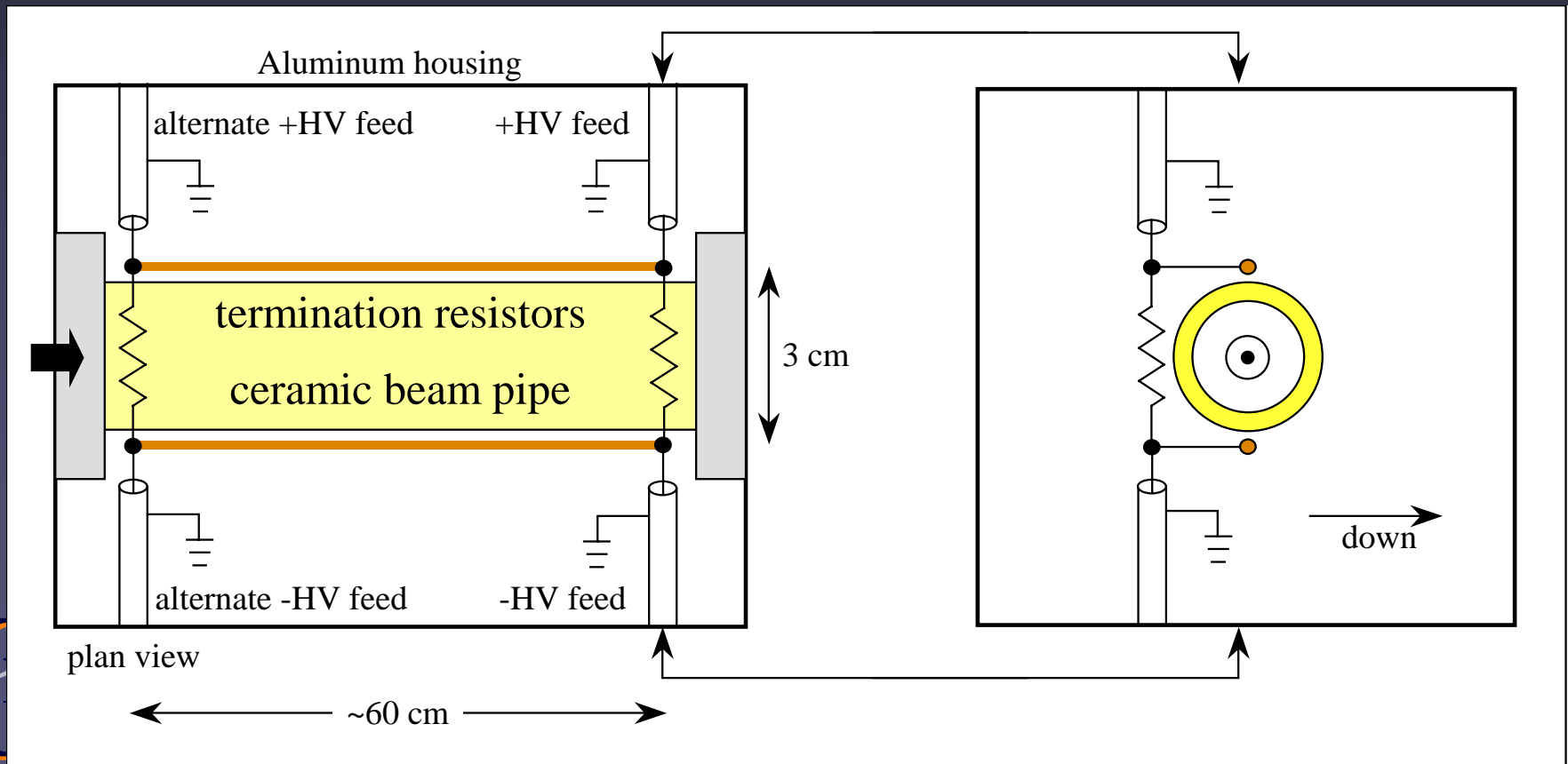

# Simple kicker instrumentation

Most kicker parts are on hand at Fermilab. SLAC is sending us a ceramic vacuum pipe which is already flanged.

We would like to assemble the kicker, developing instrumentation to measure (“on the bench”) its field strength and time dependence in collaboration with Fermilab’s technical division.

After we feel we understand the kicker we would like to install it in the A0 beam to measure its properties there.

# Rough estimate of running time

The performance demands on a real TESLA damping ring kicker are shown in the following table.

quantity	value	precision
kicking field integral	100 Gauss-meters	$\pm 0.07$ Gauss-meters
"off" field integral	0	$\pm 0.07$ Gauss-meters
kicking pulse "flattop"	at least 40 ps	
pulse rise time	less than 6 ns	
pulse fall time	less than 64 ns	

# Rough estimate of running time

A most naïve calculation is based on the estimated 3% single pulse accuracy from the BPM's and the kicker stability goal of 0.07%.

If only BPM precision contributed to the measurement uncertainties (we should be so lucky!), it would take  $(3\% / 0.07\%)^2 \approx 2000$  pulses per measurement point to reach this level of accuracy.

Arbitrarily increasing this by a factor of three to 6000 pulses would allow the 10 Hz A0 repetition rate to deliver one point's data in 10 minutes.

A scan of 100 points in which the relative timing of the arrival of the beam and the firing of the kicker is varied could be done in a few shifts.

# Summary/conclusions

We will be able to refine our estimate of required running time after constructing the kicker and making various bench tests.

We have requested Fermilab technical support for construction of the kicker HV supply and assembly of the device.

An installation date in the A0 photoinjector beam will depend on the resources Fermilab is able to provide. A rough guess is that installation in late September is feasible.