

| | | | |
|-------|-----------------------------|--------------------------------------|---------|
| Title | | VME021 - CC ANALOG TILE CARD VME BDA | |
| Size | Document Number | Rev | |
| B | 005-7164 | A | |
| Date | Thursday, February 11, 1999 | Sheet | 1 of 19 |

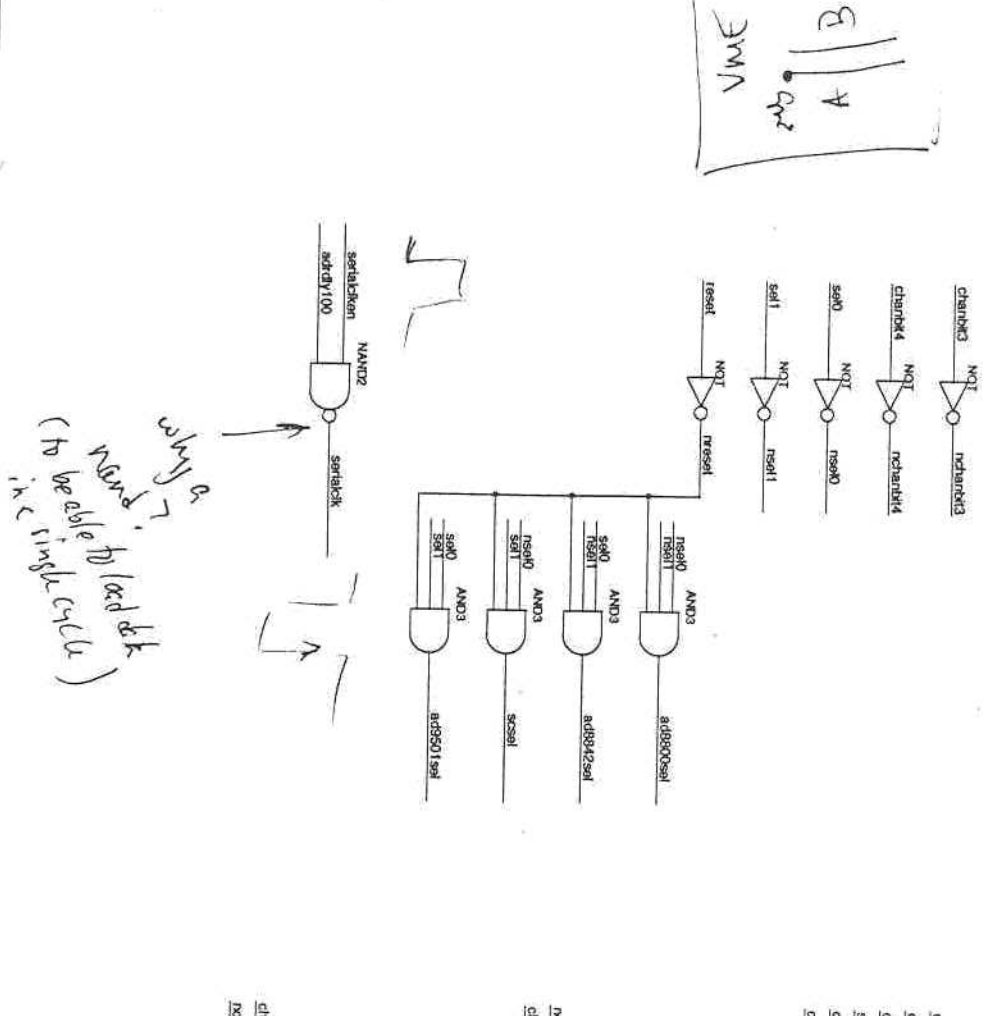

TEST PULSE TIMING DAC CONTROLS

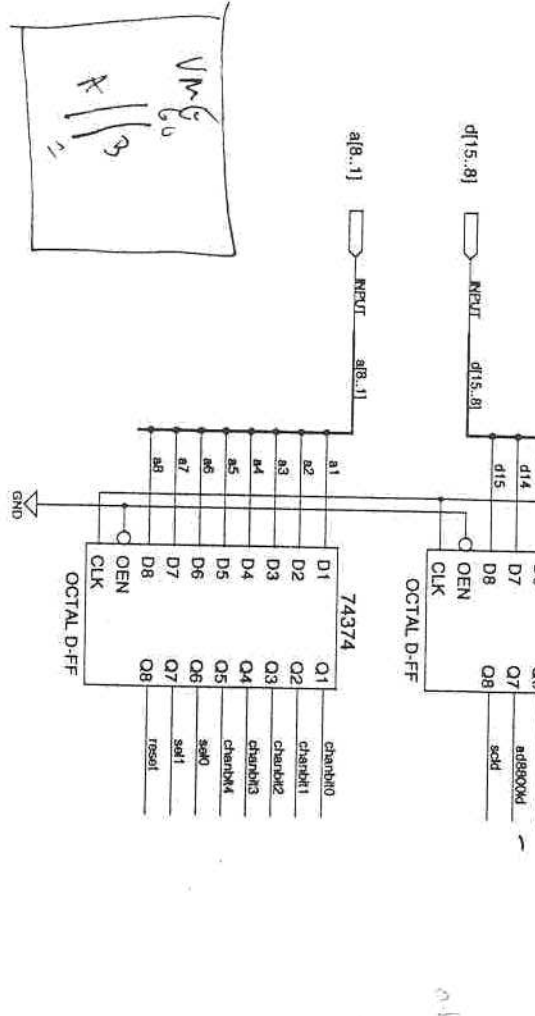
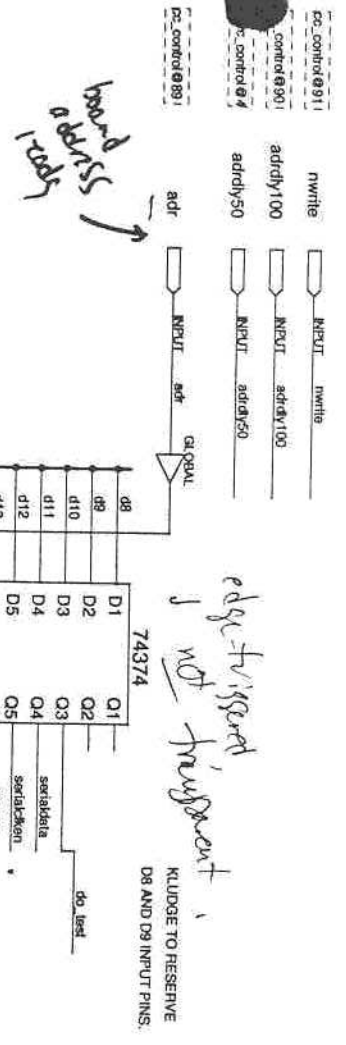
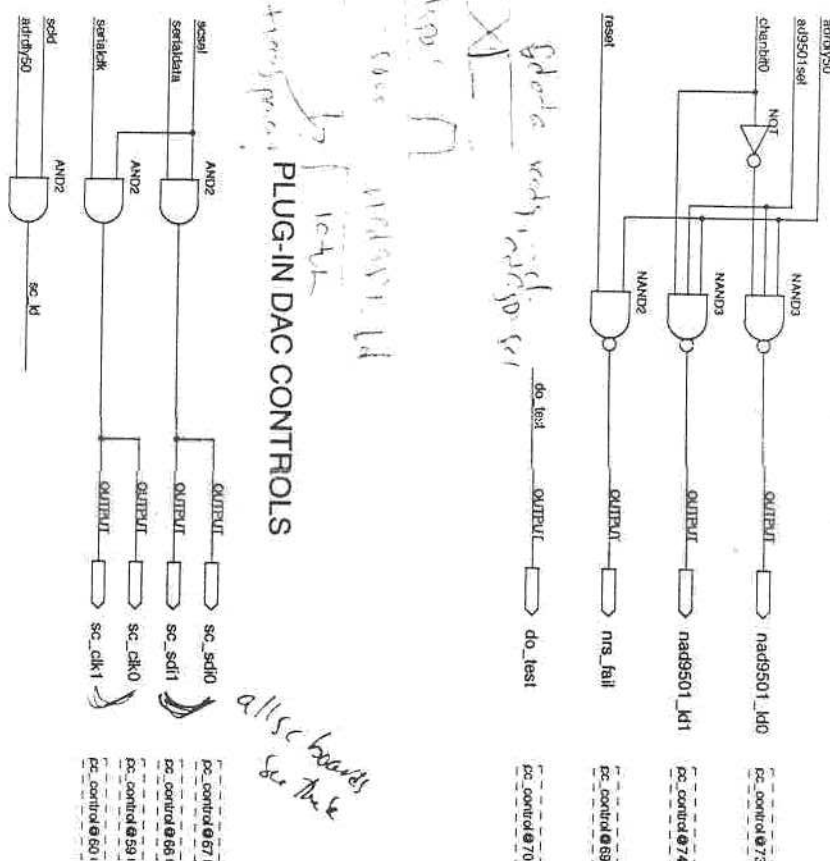

THRESHOLD DAC CONTROLS

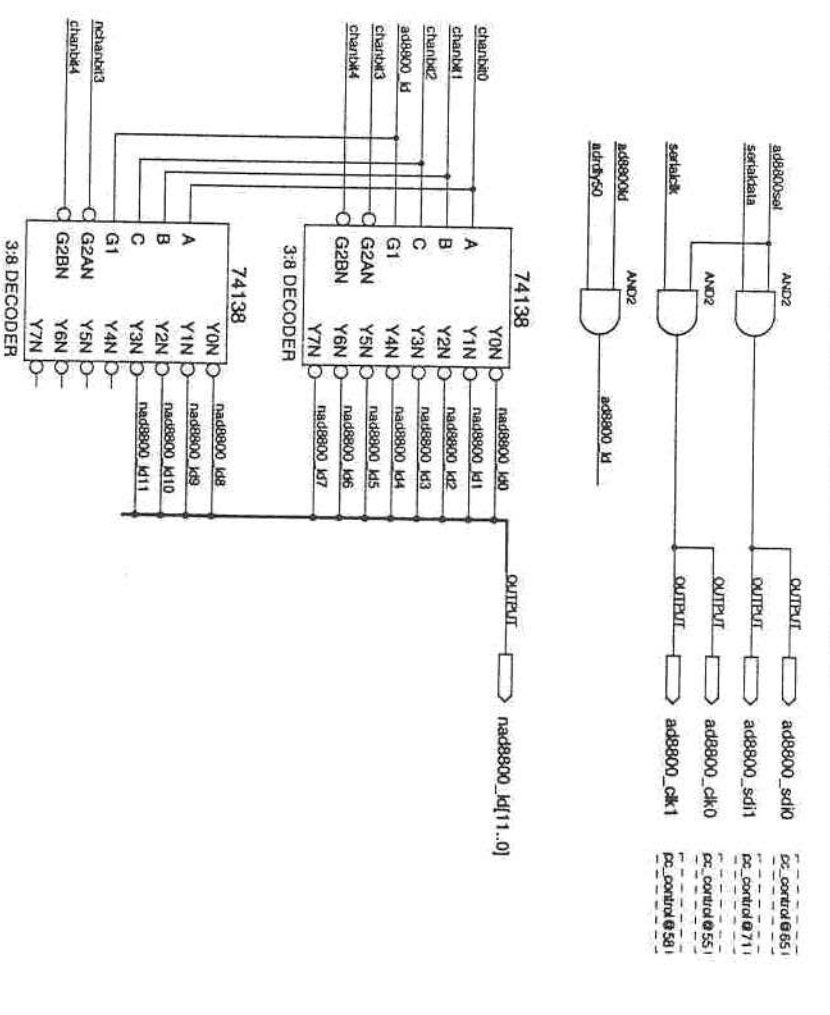

TEST PULSE AMPLITUDE DAC CONTROLS

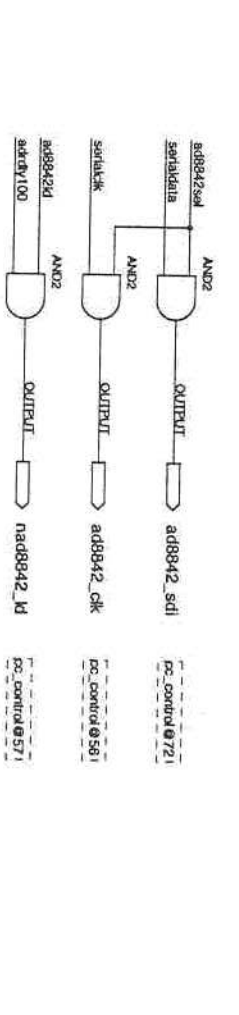

READBACK LATCHES CONTROLS

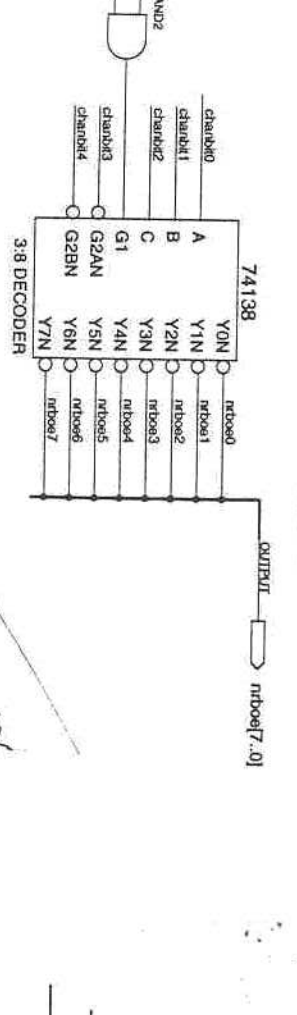

AD8842 on p. 9
Control input: p. 14.

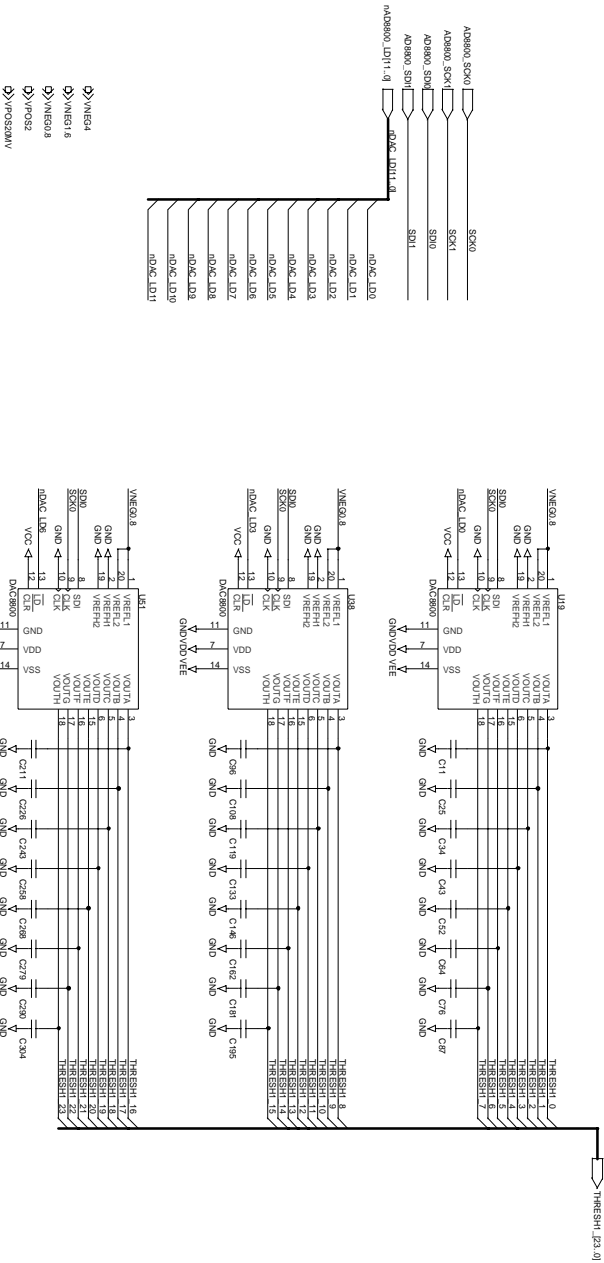

ALL CAP 0.1UF

- ⊗ VMEQ4
- ⊗ VMEQ1#
- ⊗ VMEQ2#
- ⊗ VMEQ3#
- ⊗ VMEQ2
- ⊗ VMEQ3#W

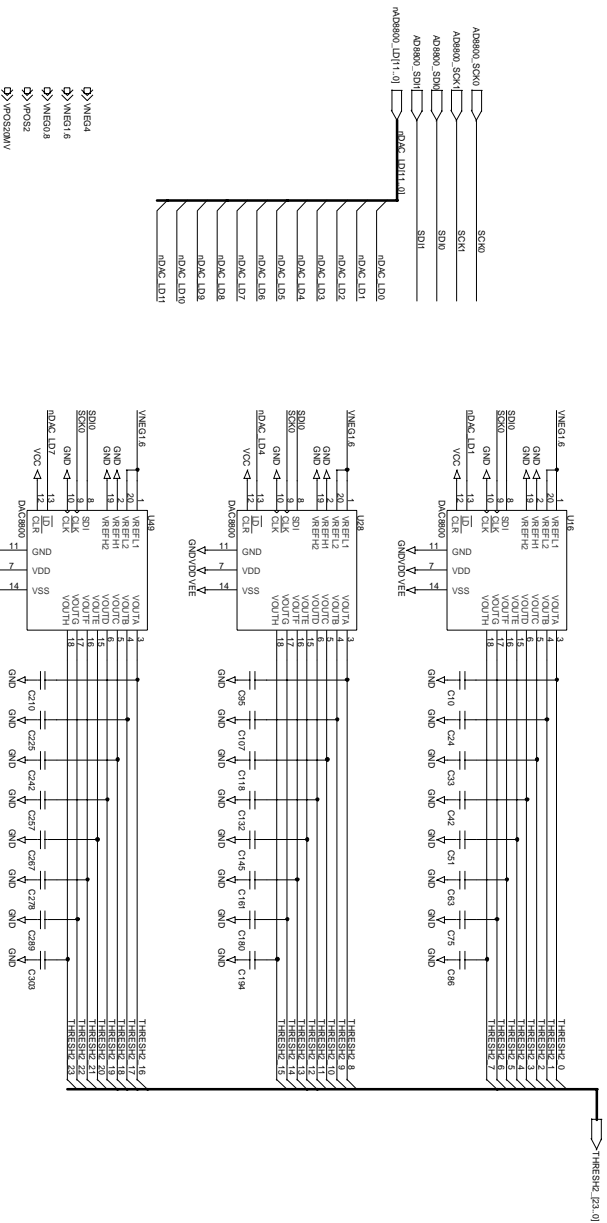

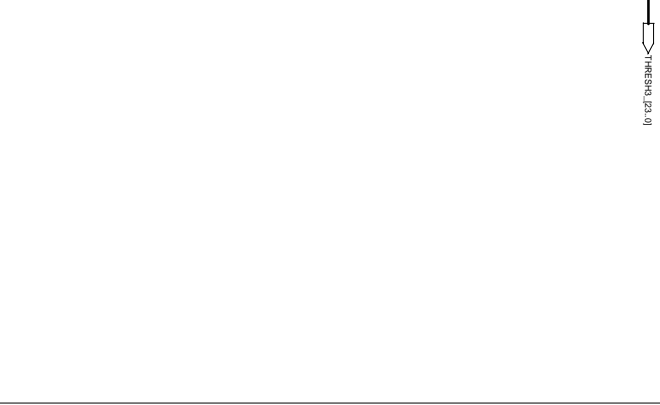
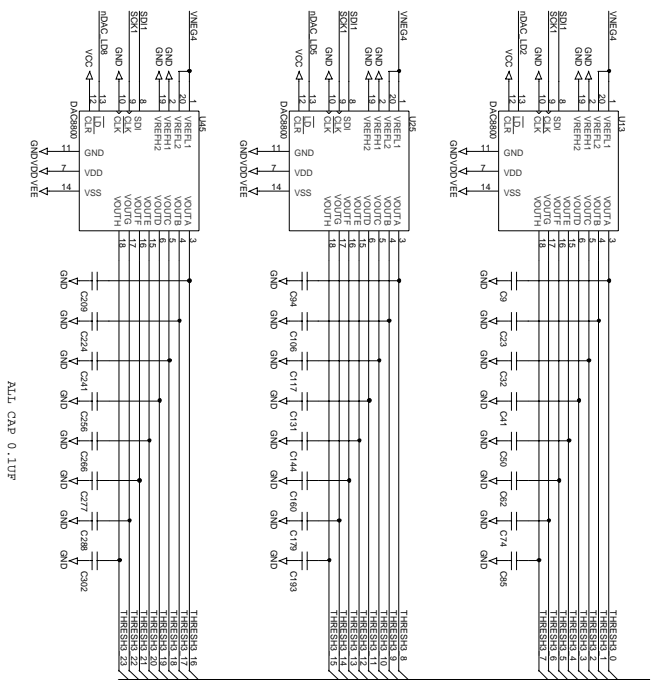
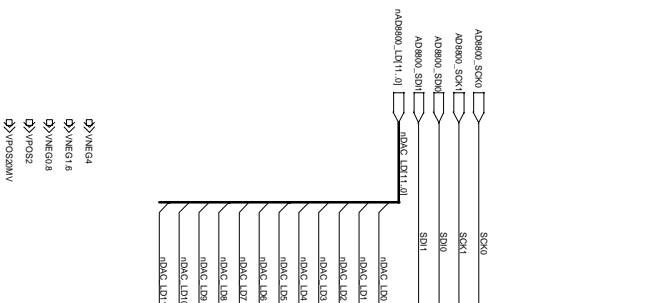

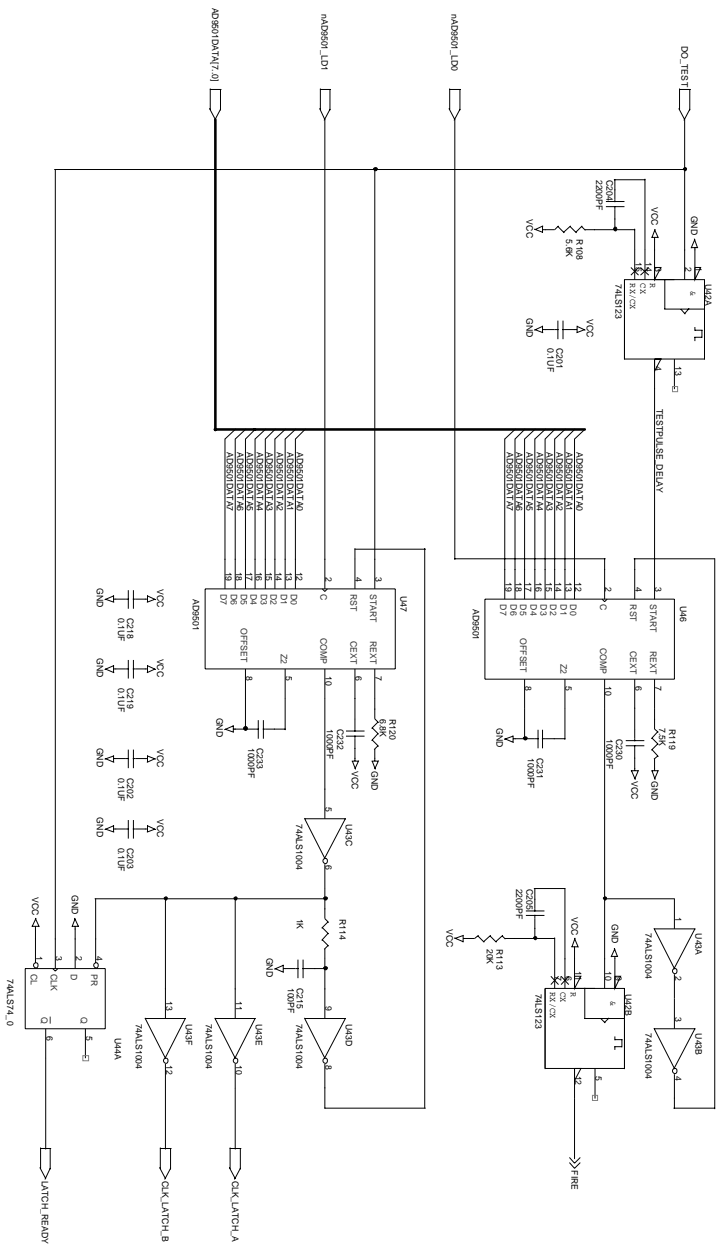

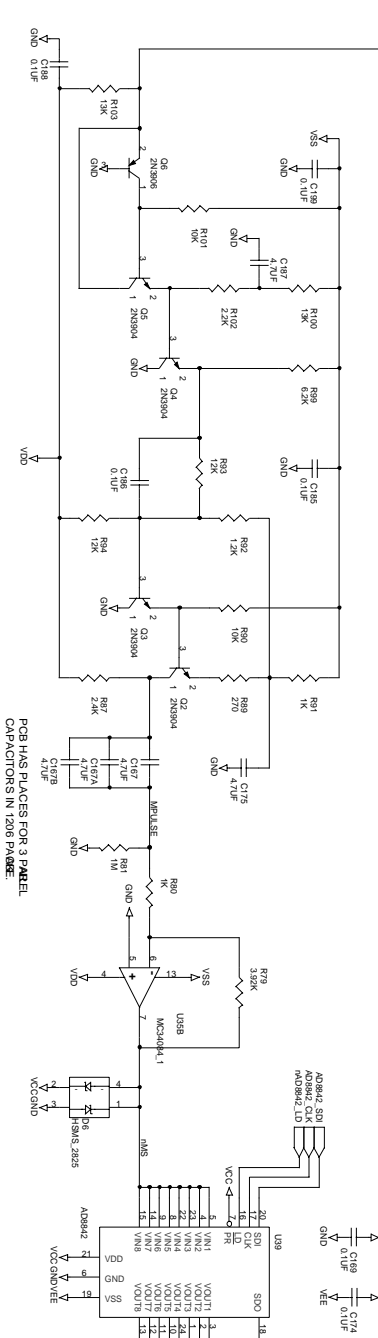
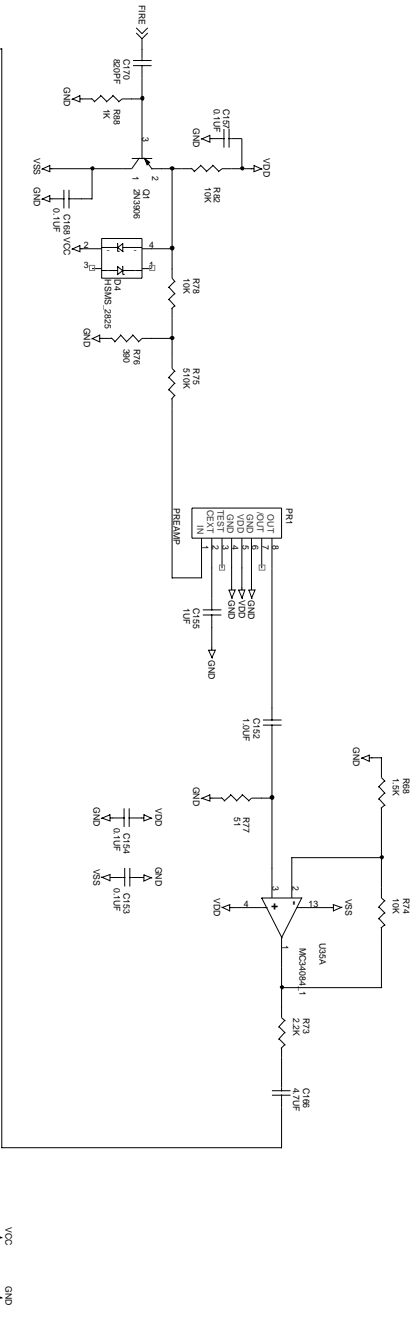

PCB HAS PLACES FOR 3 PARALLEL CAPACITORS IN I2016 PACKAGE

| | |
|-------|------------------------------|
| File | VME021 - TEST PULSER R02 |
| Size | Document Number |
| B | 0057-1-04 |
| Date | Wednesday, February 10, 1999 |
| Sheet | 10 of 10 |
| Rev | A |

CLK LATCH A

DATAOUT15 (0)



DATAOUT14

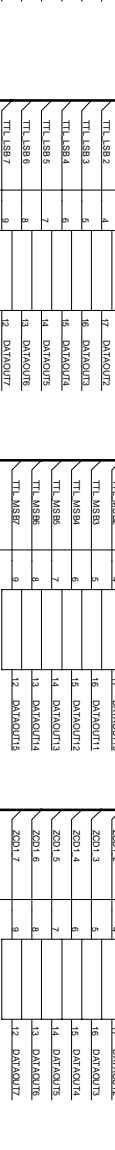

DATAOUT13



DATAOUT12



DATAOUT11

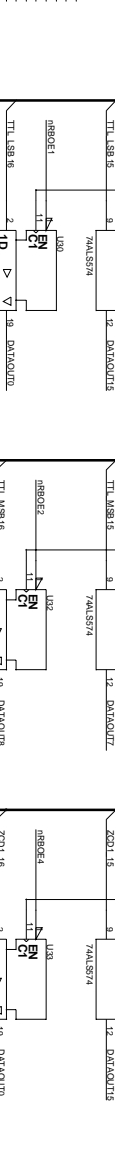

DATAOUT10



DATAOUT9

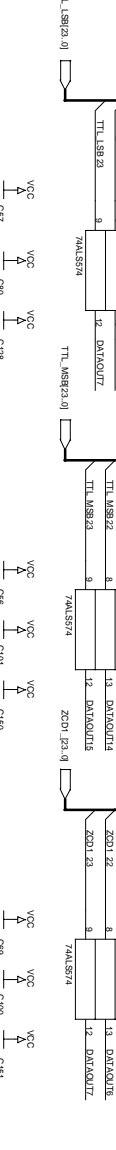

DATAOUT8

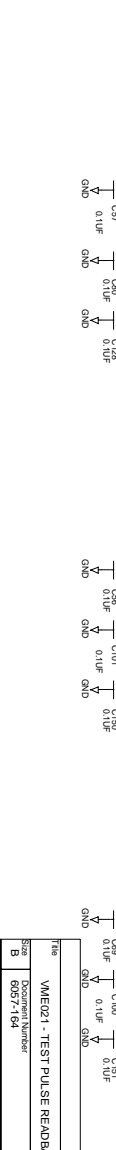

DATAOUT7



DATAOUT6



DATAOUT5

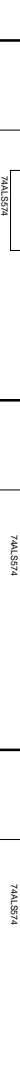

DATAOUT4



DATAOUT3



DATAOUT2



DATAOUT1



DATAOUT0

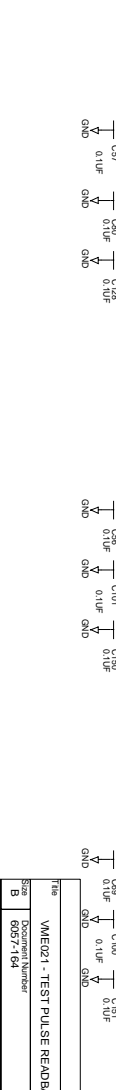

DATAOUT15 (1)

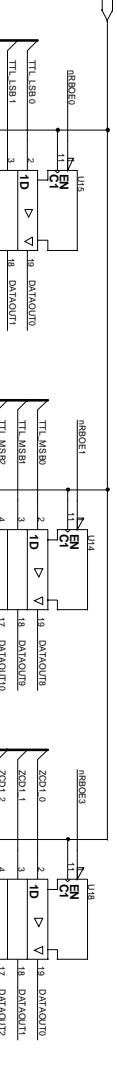

DATAOUT14

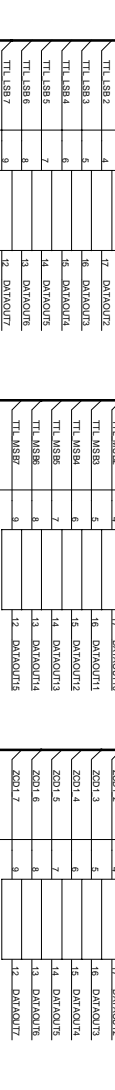

DATAOUT13

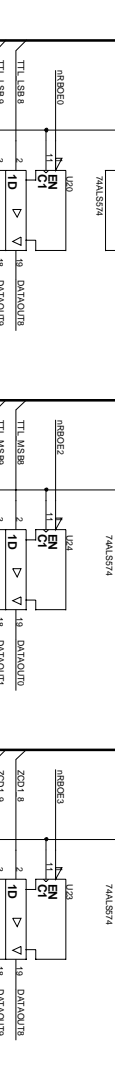

DATAOUT12

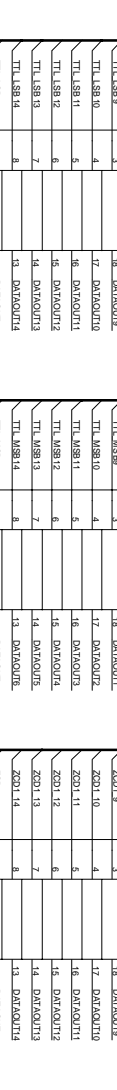

DATAOUT11

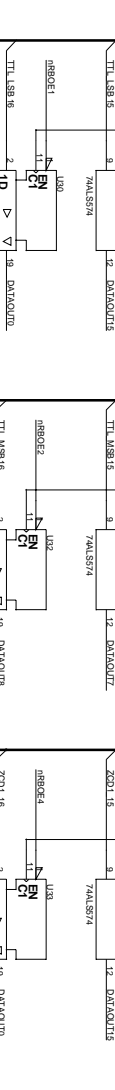

DATAOUT10

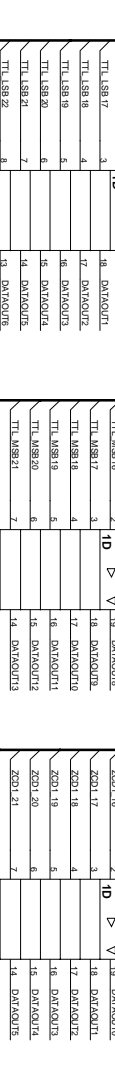

DATAOUT9

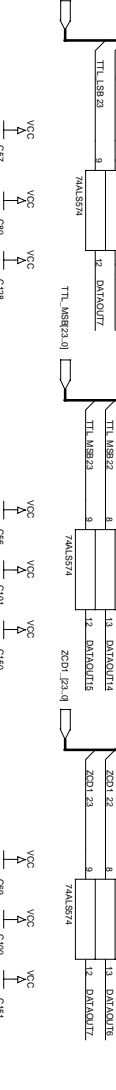

DATAOUT8

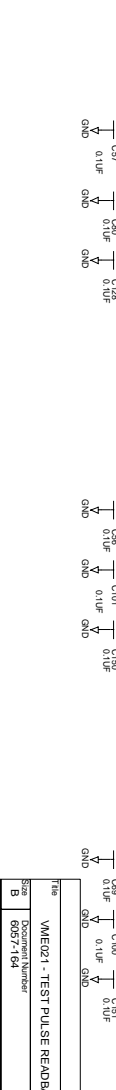

DATAOUT7



DATAOUT6



DATAOUT5

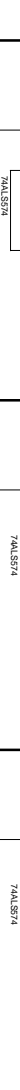

DATAOUT4



DATAOUT3



DATAOUT2



DATAOUT1



DATAOUT0

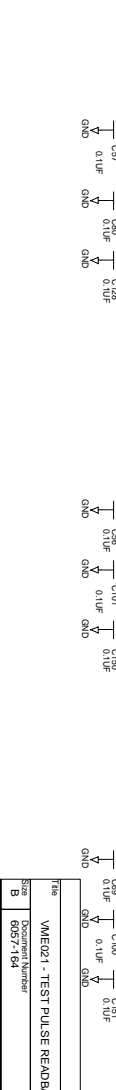

DATAOUT15 (2)

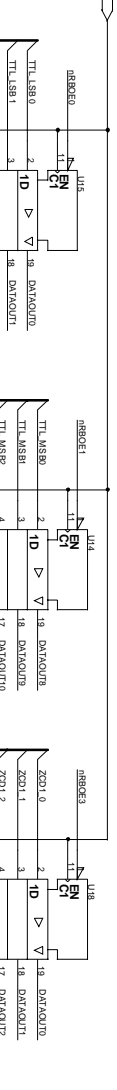

DATAOUT14

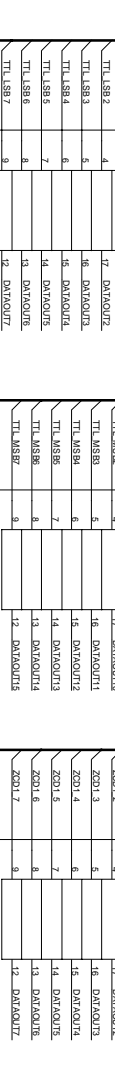

DATAOUT13

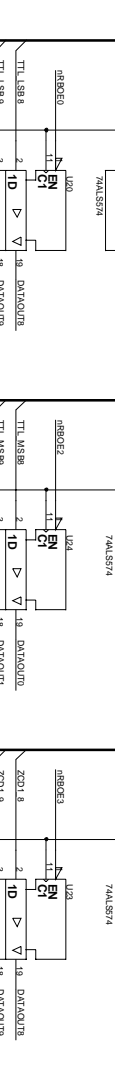

DATAOUT12

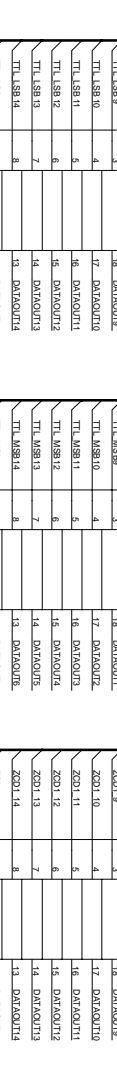

DATAOUT11

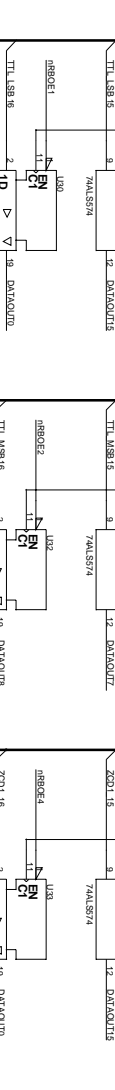

DATAOUT10

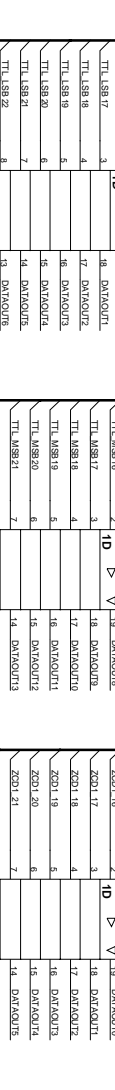

DATAOUT9

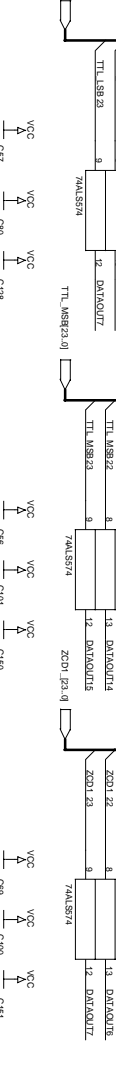

DATAOUT8

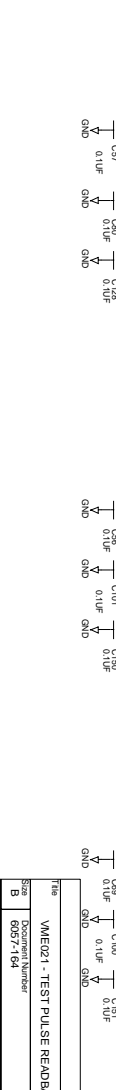

DATAOUT7



DATAOUT6



DATAOUT5

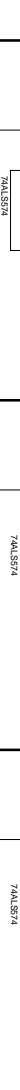

DATAOUT4



DATAOUT3



DATAOUT2



DATAOUT1



DATAOUT0

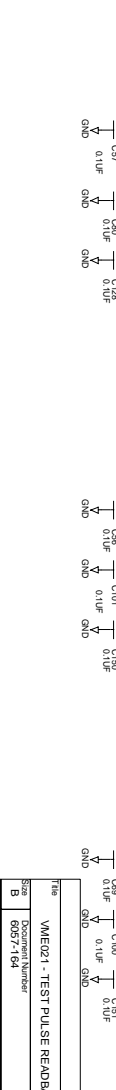

DATAOUT15 (3)

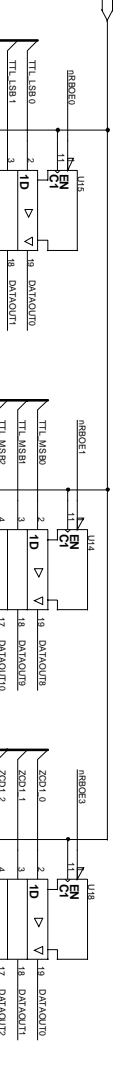

DATAOUT14

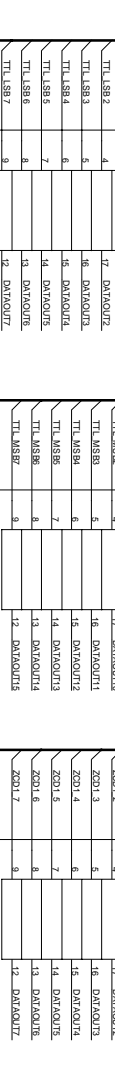

DATAOUT13

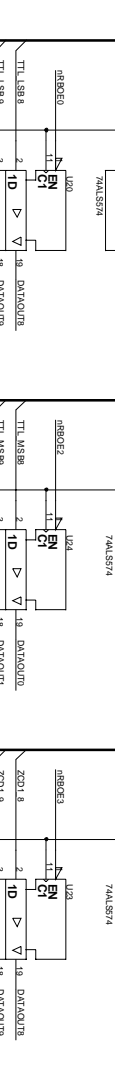

DATAOUT12

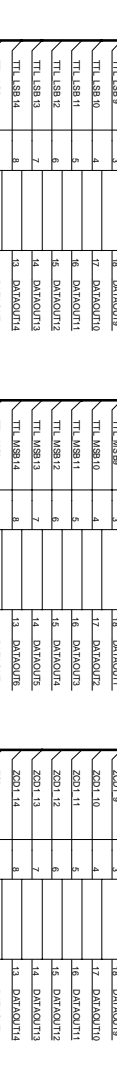

DATAOUT11

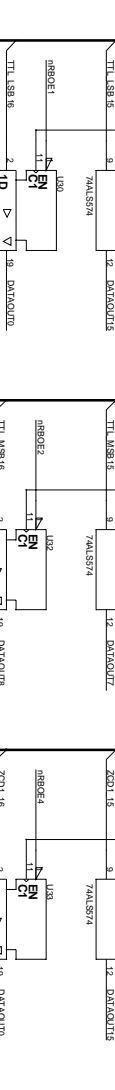

DATAOUT10

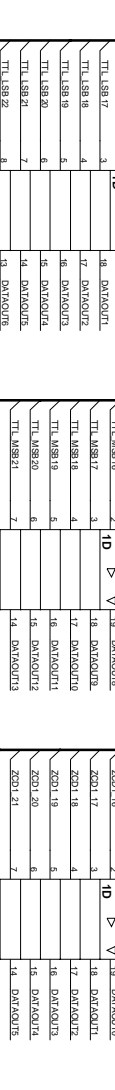

DATAOUT9

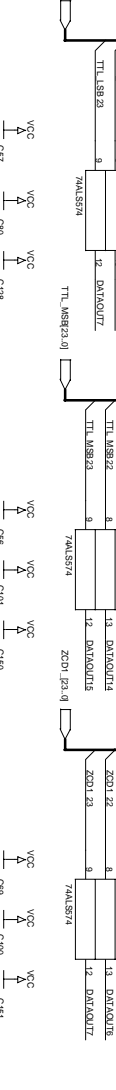

DATAOUT8

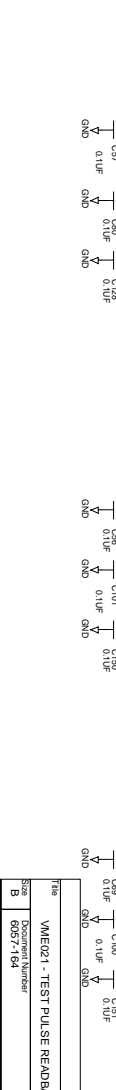

DATAOUT7



DATAOUT6



DATAOUT5



DATAOUT4



DATAOUT3



DATAOUT2



DATAOUT1



DATAOUT0

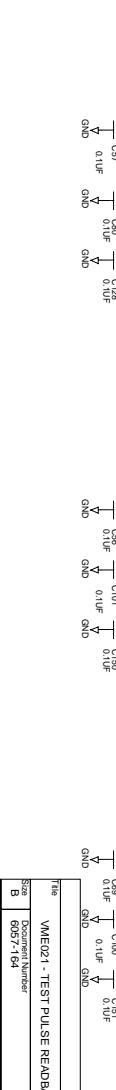

DATAOUT15 (4)

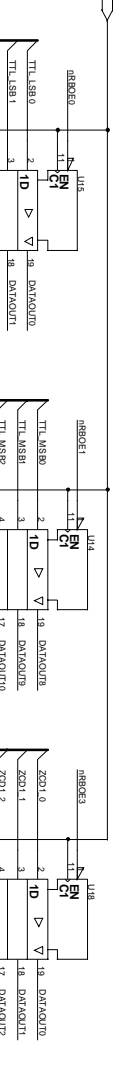

DATAOUT14

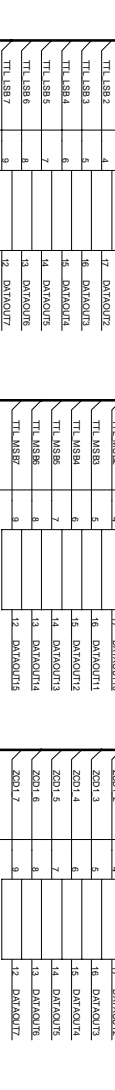

DATAOUT13

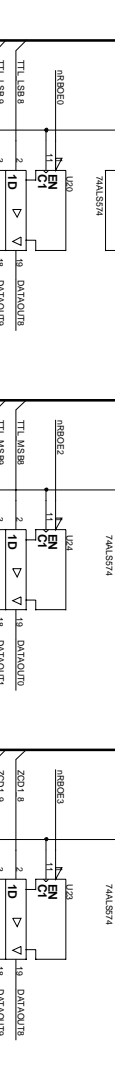

DATAOUT12

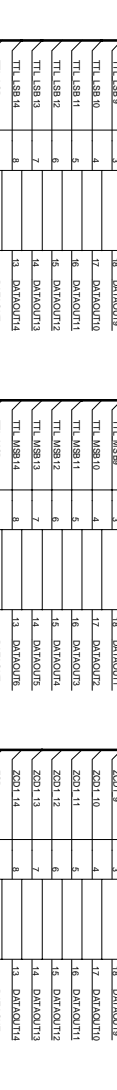

DATAOUT11

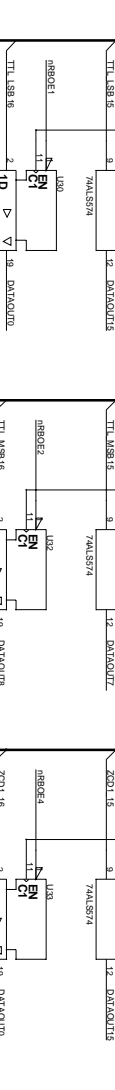

DATAOUT10

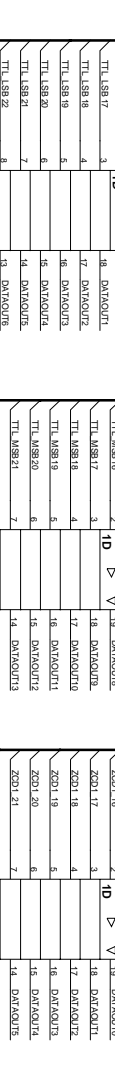

DATAOUT9

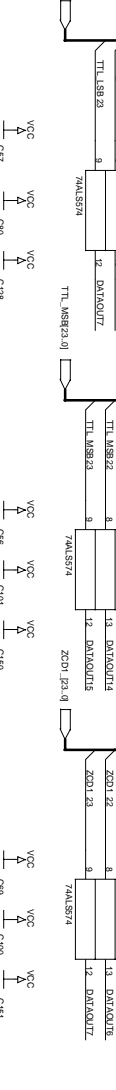

DATAOUT8

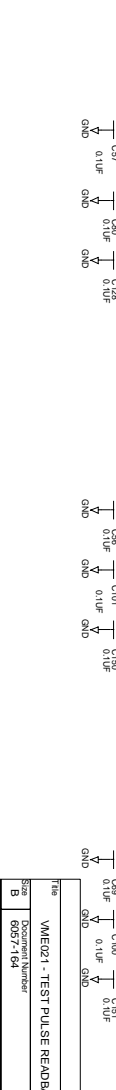

DATAOUT7



DATAOUT6



DATAOUT5

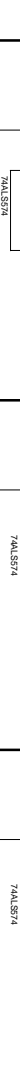

DATAOUT4



DATAOUT3



DATAOUT2



DATAOUT1



DATAOUT0

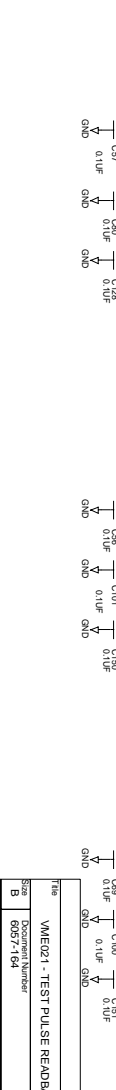

DATAOUT15 (5)

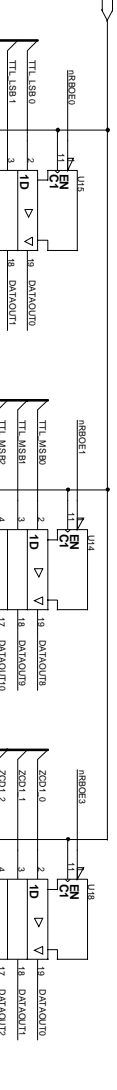

DATAOUT14

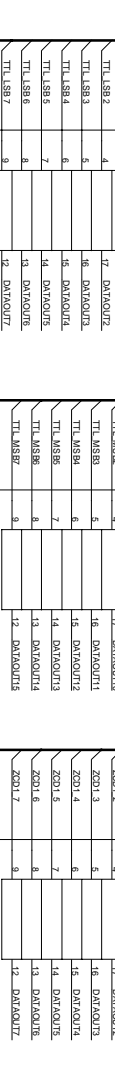

DATAOUT13

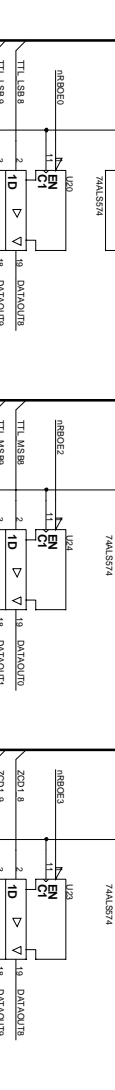

DATAOUT12

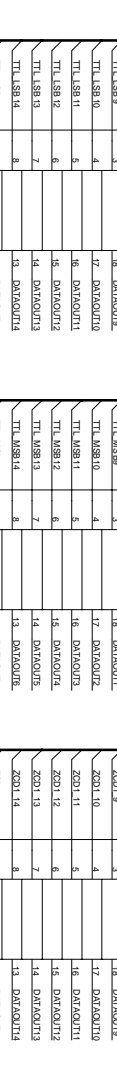

DATAOUT11

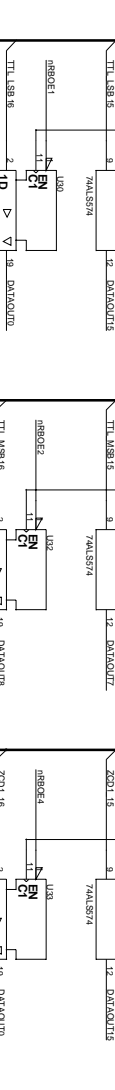

DATAOUT10

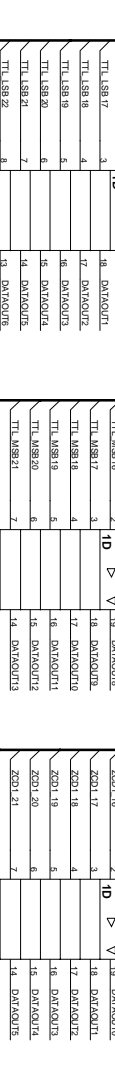

DATAOUT9

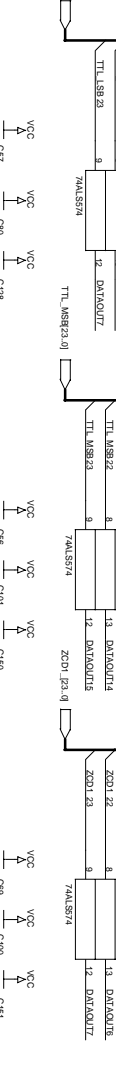

DATAOUT8

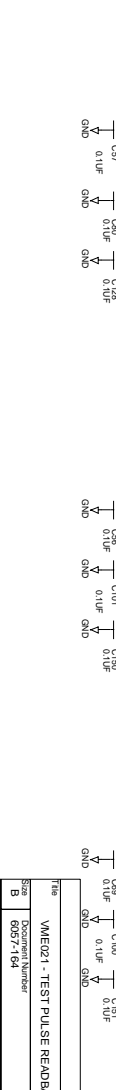

DATAOUT7



DATAOUT6



DATAOUT5



DATAOUT4



DATAOUT3



DATAOUT2



DATAOUT1



DATAOUT0

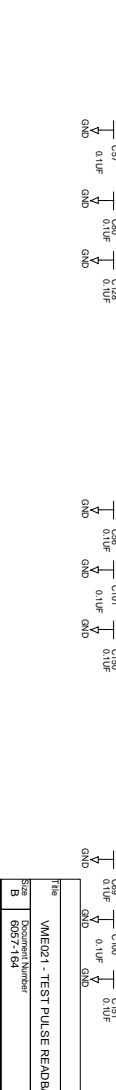

DATA

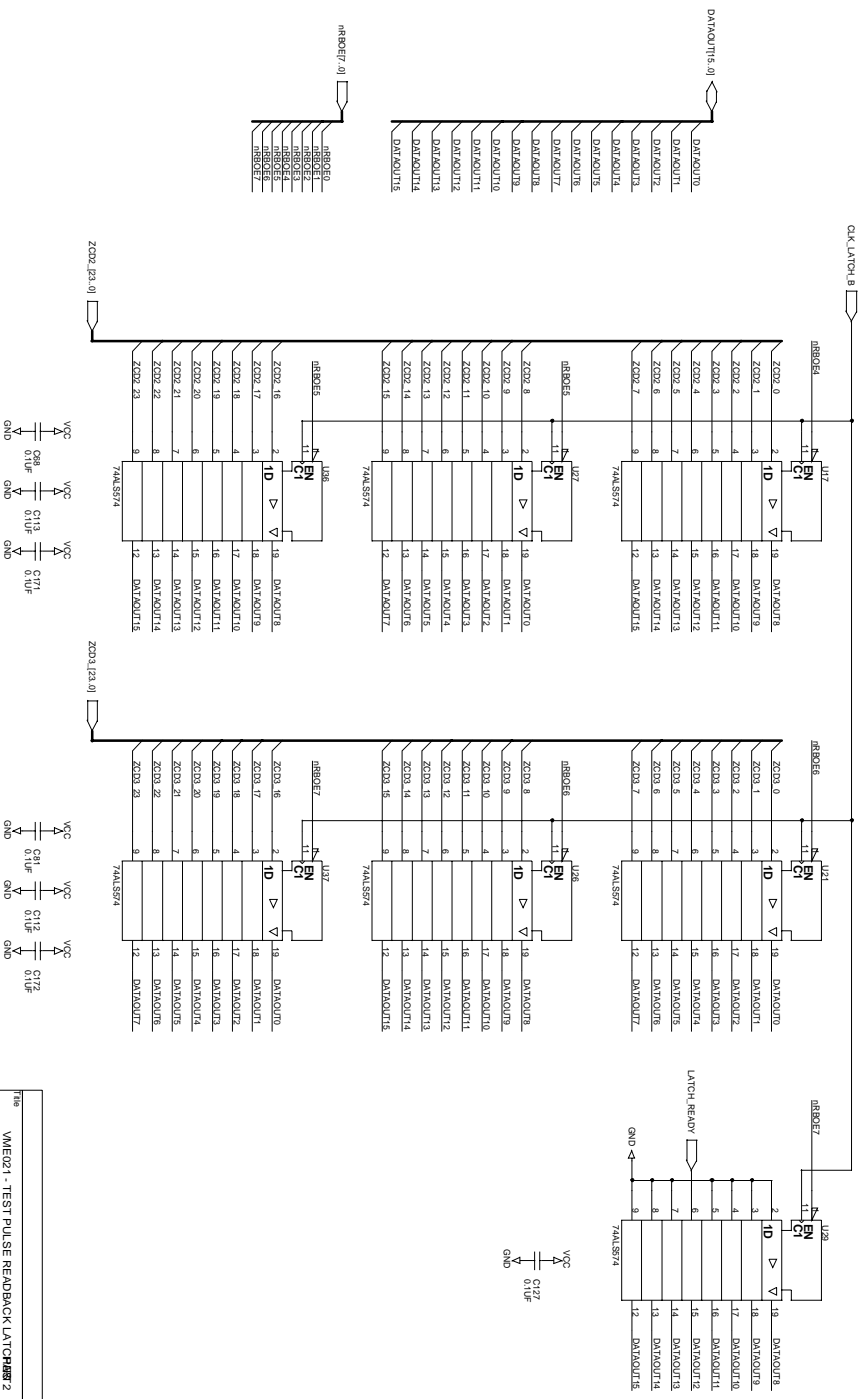

CLK LATCH_B

DATAOUT[31:0]

DATAOUT[7:0]

DATAOUT[15:8]

DATAOUT[23:16]

DATAOUT[31:24]

LATCH_READY

DATAOUT[7:0]

DATAOUT[15:8]

DATAOUT[23:16]

DATAOUT[31:24]

VCC
A
C127
0.1µF
GND

VCC
A
C23
0.1µF
GND

VCC
A
C113
0.1µF
GND

| | |
|-------|--|
| Title | VM6021 - TEST PULSE READBACK LATCHES 2 |
| Size | Document Number |
| B | 00577-104 |
| Date | Wednesday, February 10, 1999 |
| Sheet | 12 of 13 |
| Rev | A |

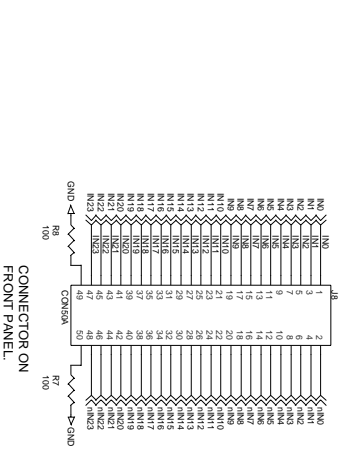

- NI0 RIU PSES mNI0
- NI1 RIU PSES mNI1
- NI2 RIU PSES mNI2
- NI3 RIU PSES mNI3
- NI4 RIU PSES mNI4
- NI5 RIU PSES mNI5
- NI6 RIU PSES mNI6
- NI7 RIU PSES mNI7
- NI8 RIU PSES mNI8
- NI9 RIU PSES mNI9
- NI10 RIU PSES mNI10
- NI11 RIU PSES mNI11
- NI12 RIU PSES mNI12
- NI13 RIU PSES mNI13
- NI14 RIU PSES mNI14
- NI15 RIU PSES mNI15
- NI16 RIU PSES mNI16
- NI17 RIU PSES mNI17
- NI18 RIU PSES mNI18
- NI19 RIU PSES mNI19
- NI20 RIU PSES mNI20
- NI21 RIU PSES mNI21
- NI22 RIU PSES mNI22
- NI23 RIU PSES mNI23

CONNECTORS ON
FRONT PANEL.

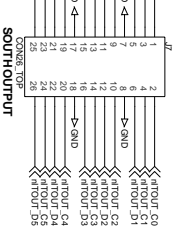
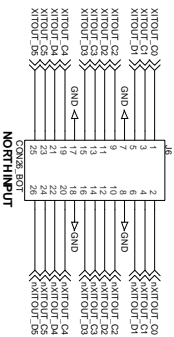

CONNECTORS ON
FRONT PANEL.

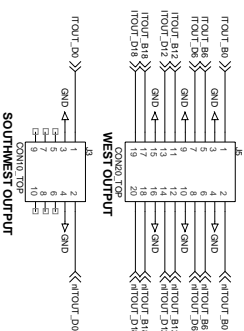
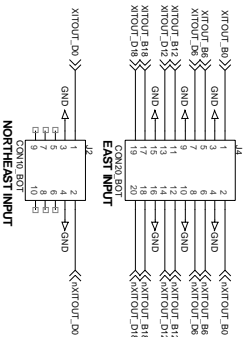

NORTHEAST INPUT

SOUTHWEST OUTPUT

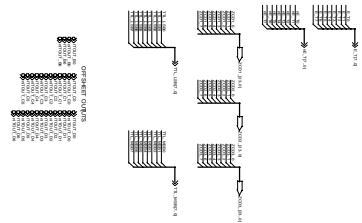
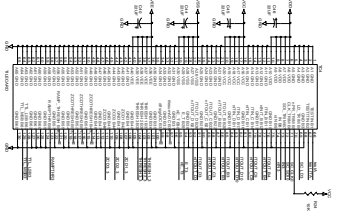
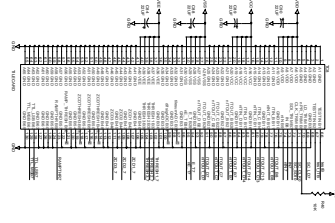
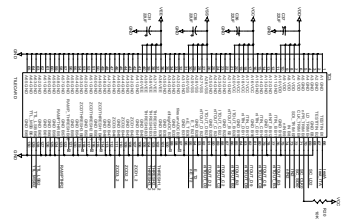
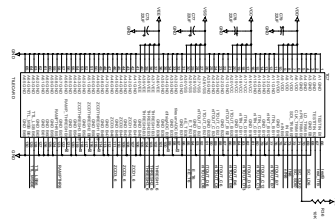
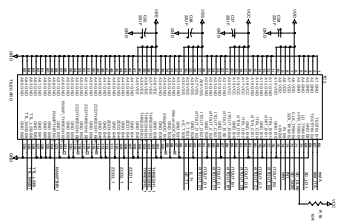
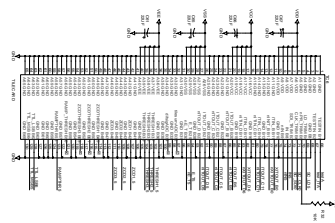
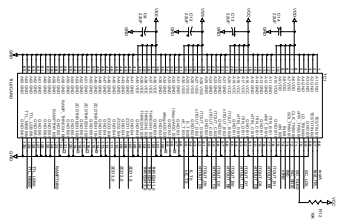
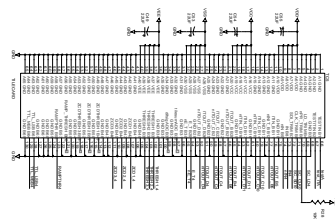
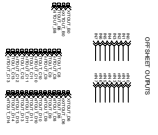
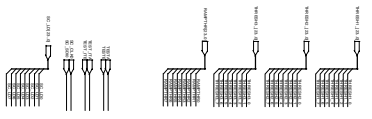

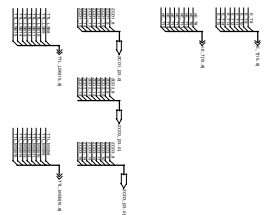
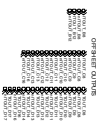
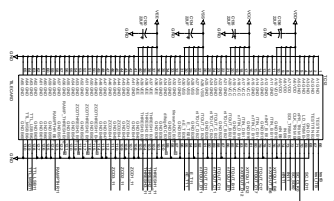
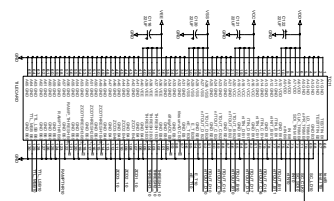
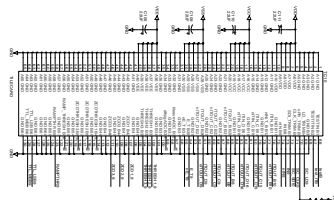
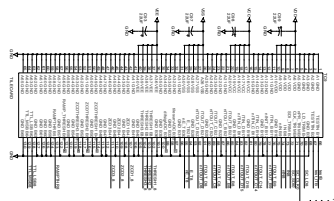
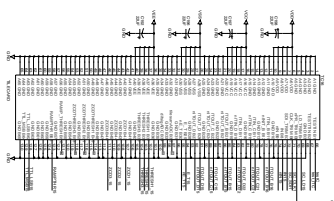
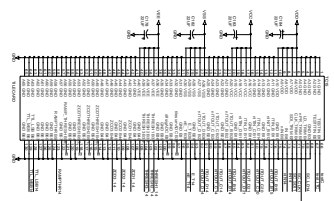
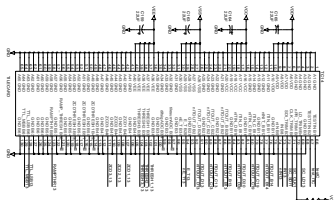
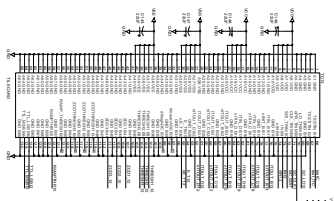
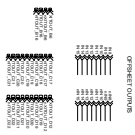
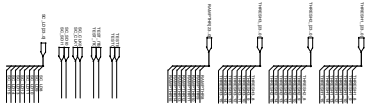

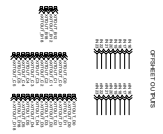
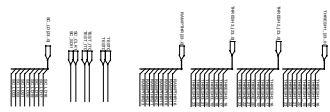
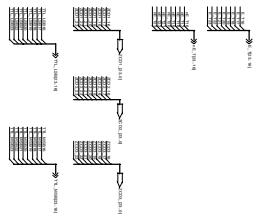
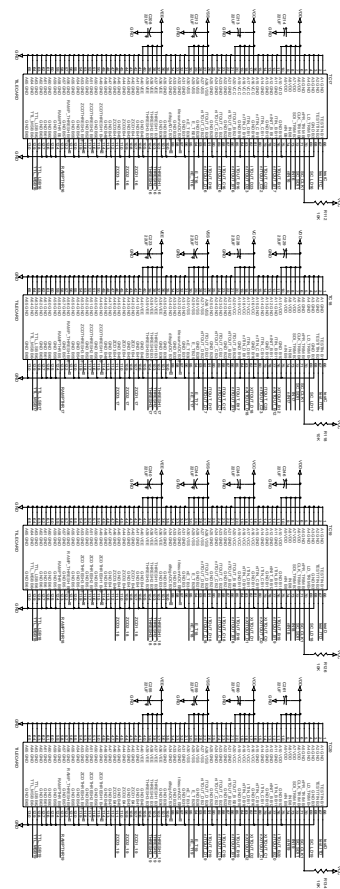
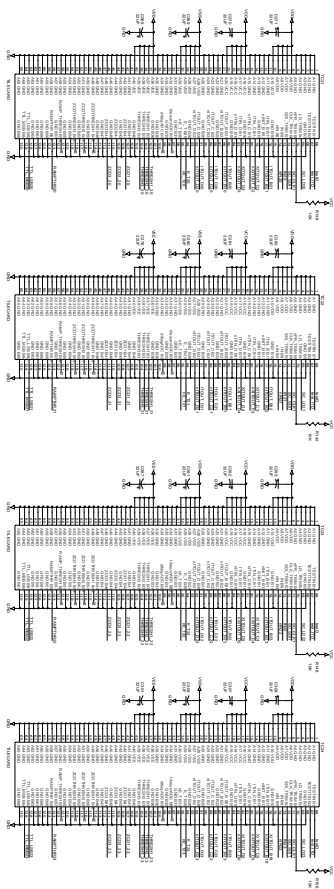

SMT0288880