

SN54F51, SN74F51

DUAL 2-WIDE 2-INPUT, 2-WIDE 3-INPUT AND-OR-INVERT GATES

SDFS092 – JANUARY 1989 – REVISED OCTOBER 1993

- Package Options Include Plastic Small-Outline Packages, Ceramic Chip Carriers, and Standard Plastic and Ceramic 300-mil DIPs

description

These devices contain 2-wide 2-input and 2-wide 3-input AND-OR-INVERT gates. They perform the following Boolean functions:

$$1Y = \overline{(1A \cdot 1B \cdot 1C) + (1D \cdot 1E \cdot 1F)}$$

$$2Y = \overline{(2A \cdot 2B) + (2C \cdot 2D)}$$

The SN54F51 is characterized for operation over the full military temperature range of -55°C to 125°C . The SN74F51 is characterized for operation from 0°C to 70°C .

FUNCTION TABLES

GATE 1

INPUTS						OUTPUT
1A	1B	1C	1D	1E	1F	1Y
H	H	H	X	X	X	L
X	X	X	H	H	H	L
All other combinations						H

GATE 2

INPUTS				OUTPUT
2A	2B	2C	2D	2Y
H	H	X	X	L
X	X	H	H	L
All other combinations				H

SN54F51 ... J PACKAGE SN74F51 ... D OR N PACKAGE (TOP VIEW)

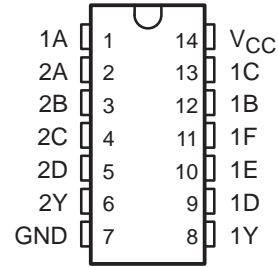

SN54F51 ... FK PACKAGE (TOP VIEW)

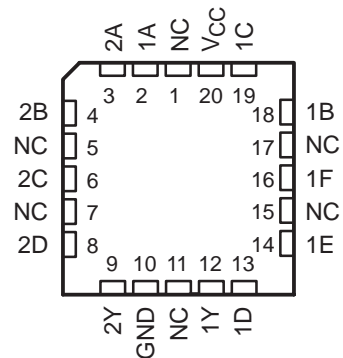

NC – No internal connection

SN54F51, SN74F51 DUAL 2-WIDE 2-INPUT, 2-WIDE 3-INPUT AND-OR-INVERT GATES

SDFS092 – JANUARY 1989 – REVISED OCTOBER 1993

logic symbol†

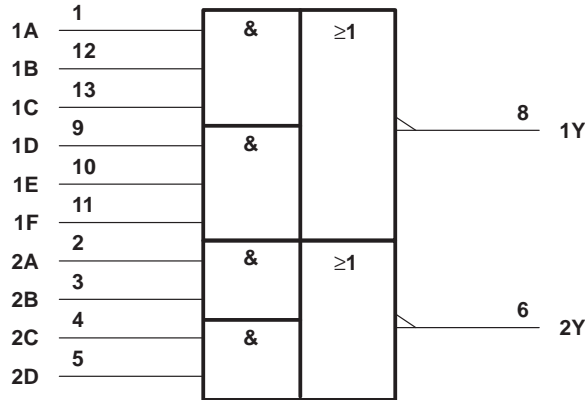

† This symbol is in accordance with ANSI/IEEE Std 91-1984 and IEC Publication 617-12.
Pin numbers shown are for the D, J, and N packages.

logic diagram (positive logic)

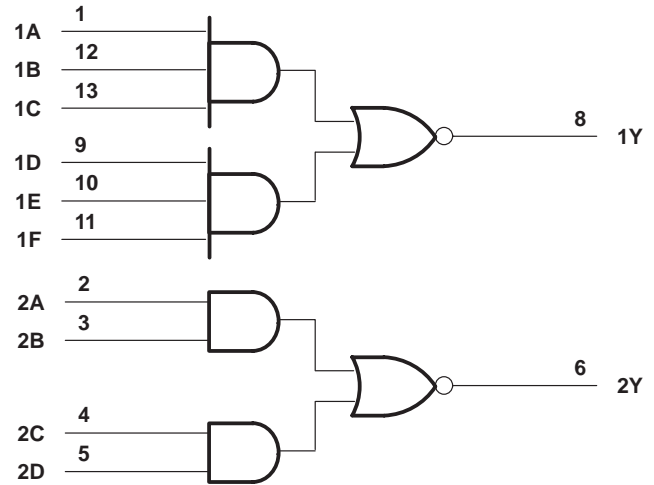

absolute maximum ratings over operating free-air temperature range (unless otherwise noted)‡

Supply voltage range, V_{CC}	-0.5 V to 7 V
Input voltage range, V_I (see Note 1)	-1.2 V to 7 V
Input current range	-30 mA to 5 mA
Voltage range applied to any output in the high state	-0.5 V to V_{CC}
Current into any output in the low state	40 mA
Operating free-air temperature range: SN54F51	-55°C to 125°C
SN74F51	0°C to 70°C
Storage temperature range	-65°C to 150°C

‡ Stresses beyond those listed under "absolute maximum ratings" may cause permanent damage to the device. These are stress ratings only and functional operation of the device at these or any other conditions beyond those indicated under "recommended operating conditions" is not implied. Exposure to absolute-maximum-rated conditions for extended periods may affect device reliability.

NOTE 1: The input voltage ratings may be exceeded provided the input current ratings are observed.

recommended operating conditions

	SN54F51			SN74F51			UNIT
	MIN	NOM	MAX	MIN	NOM	MAX	
V_{CC} Supply voltage	4.5	5	5.5	4.5	5	5.5	V
V_{IH} High-level input voltage	2			2			V
V_{IL} Low-level input voltage			0.8			0.8	V
I_{IK} Input clamp current			-18			-18	mA
I_{OH} High-level output current			-1			-1	mA
I_{OL} Low-level output current			20			20	mA
T_A Operating free-air temperature	-55		125	0		70	°C

SN54F51, SN74F51

DUAL 2-WIDE 2-INPUT, 2-WIDE 3-INPUT AND-OR-INVERT GATES

SDFS092 – JANUARY 1989 – REVISED OCTOBER 1993

electrical characteristics over recommended operating free-air temperature range (unless otherwise noted)

PARAMETER	TEST CONDITIONS		SN54F51			SN74F51			UNIT
			MIN	TYP†	MAX	MIN	TYP†	MAX	
V_{IK}	$V_{CC} = 4.5\text{ V}$,	$I_I = -18\text{ mA}$			-1.2			-1.2	V
V_{OH}	$V_{CC} = 4.5\text{ V}$,	$I_{OH} = -1\text{ mA}$	2.5	3.4		2.5	3.4		V
	$V_{CC} = 4.75\text{ V}$,	$I_{OH} = -1\text{ mA}$				2.7			
V_{OL}	$V_{CC} = 4.5\text{ V}$,	$I_{OL} = 20\text{ mA}$		0.35	0.5		0.35	0.5	V
I_I	$V_{CC} = 5.5\text{ V}$,	$V_I = 7\text{ V}$			100			100	μA
I_{IH}	$V_{CC} = 5.5\text{ V}$,	$V_I = 2.7\text{ V}$			20			20	μA
I_{IL}	$V_{CC} = 5.5\text{ V}$,	$V_I = 0.5\text{ V}$			-0.6			-0.6	mA
I_{OS}^\ddagger	$V_{CC} = 5.5\text{ V}$,	$V_O = 0$	-60		-150	-60		-150	mA
I_{CCH}	$V_{CC} = 5.5\text{ V}$,	$V_I = 0$		1.8	3		1.8	3	mA
I_{CCL}	$V_{CC} = 5.5\text{ V}$,	$V_I = 4.5\text{ V}$		5.5	7.5		5.5	7.5	mA

† All typical values are at $V_{CC} = 5\text{ V}$, $T_A = 25^\circ\text{C}$.

‡ Not more than one output should be shorted at a time, and the duration of the short circuit should not exceed one second.

switching characteristics (see Note 2)

PARAMETER	FROM (INPUT)	TO (OUTPUT)	$V_{CC} = 5\text{ V}$, $C_L = 50\text{ pF}$, $R_L = 500\ \Omega$, $T_A = 25^\circ\text{C}$			$V_{CC} = 4.5\text{ V to }5.5\text{ V}$, $C_L = 50\text{ pF}$, $R_L = 500\ \Omega$, $T_A = \text{MIN to MAX}^\S$				UNIT
			'F51			SN54F51		SN74F51		
			MIN	TYP	MAX	MIN	MAX	MIN	MAX	
t_{PLH}	Any input	Y	2	3.5	5.5	1.5	7.5	1.5	6.5	ns
t_{PHL}			1	2.5	4	1	5	1	4.5	

§ For conditions shown as MIN or MAX, use the appropriate value specified under recommended operating conditions.

NOTE 2: Load circuits and waveforms are shown in Section 1.

IMPORTANT NOTICE

Texas Instruments and its subsidiaries (TI) reserve the right to make changes to their products or to discontinue any product or service without notice, and advise customers to obtain the latest version of relevant information to verify, before placing orders, that information being relied on is current and complete. All products are sold subject to the terms and conditions of sale supplied at the time of order acknowledgement, including those pertaining to warranty, patent infringement, and limitation of liability.

TI warrants performance of its semiconductor products to the specifications applicable at the time of sale in accordance with TI's standard warranty. Testing and other quality control techniques are utilized to the extent TI deems necessary to support this warranty. Specific testing of all parameters of each device is not necessarily performed, except those mandated by government requirements.

CERTAIN APPLICATIONS USING SEMICONDUCTOR PRODUCTS MAY INVOLVE POTENTIAL RISKS OF DEATH, PERSONAL INJURY, OR SEVERE PROPERTY OR ENVIRONMENTAL DAMAGE ("CRITICAL APPLICATIONS"). TI SEMICONDUCTOR PRODUCTS ARE NOT DESIGNED, AUTHORIZED, OR WARRANTED TO BE SUITABLE FOR USE IN LIFE-SUPPORT DEVICES OR SYSTEMS OR OTHER CRITICAL APPLICATIONS. INCLUSION OF TI PRODUCTS IN SUCH APPLICATIONS IS UNDERSTOOD TO BE FULLY AT THE CUSTOMER'S RISK.

In order to minimize risks associated with the customer's applications, adequate design and operating safeguards must be provided by the customer to minimize inherent or procedural hazards.

TI assumes no liability for applications assistance or customer product design. TI does not warrant or represent that any license, either express or implied, is granted under any patent right, copyright, mask work right, or other intellectual property right of TI covering or relating to any combination, machine, or process in which such semiconductor products or services might be or are used. TI's publication of information regarding any third party's products or services does not constitute TI's approval, warranty or endorsement thereof.